



INSTALLATION INSTRUCTIONS

UNIT No. 161/761 THIN-LINE SHOWER ENCLOSURE



MAINTENANCE: Two primary materials are used to manufacture your new Basco enclosure: tempered glass and anodized aluminum. To assure a long lasting finish on the enclosure, wipe it down with a towel after each use. Never use a scouring agent to clean the aluminum.

For occasional, more concentrated cleaning efforts, we find that *Lysol Bathroom Cleaner* works extremely well. Be sure that any over spray falling on the aluminum frame is rinsed thoroughly and dried. Many over-the-counter cleaners, if applied to the aluminum and left on, will harm the metal finish and cause permanent damage, even though their directions indicate safe use on shower doors.

INSTALLATION NOTES: Unpack your unit carefully and inspect for freight damage. Lay out and identify all parts using the instruction sheets as a reference. Before discarding the carton, check to see that no small hardware parts have fallen to the bottom of the box. If any parts are damaged or missing, refer to the descriptions noted in the instructions when contacting your dealer for replacements.

Handle the glass panels carefully and protect the edges.

Please wear safety glasses whenever drilling or cutting. When drilling holes in the ceramic tile or marble, use a center punch and hammer to carefully break the surface glaze so the drill can start without skidding.

To install your BASCO Shower Door you will need the following: tape measure, level, #2 Phillips screwdriver, drill, 3/16" wrench, 1/8" and 3/16" drill bits, hacksaw, pencil, and caulking (clear silicone recommended). Optional tools include a miter box for cutting parts to length, files, center punch, and masking tape.

For drilling tile a 3/16" masonry bit is recommended.

NOTE: Tempered glass cannot be cut.

Although safety tempered glass is very resistant to breakage, the glass can still break if unequal pressure is placed on it during installation. Use caution. In addition, the sharp corners of the panels can damage tile and floor surfaces, so it is best to handle the glass panels carefully and protect the edges.

IDENTIFICATION GROOVE

NOTE: Each magnetic strip has an identification groove on the exposed surface. For proper alignment, the grooves should be opposite each other (see detail)

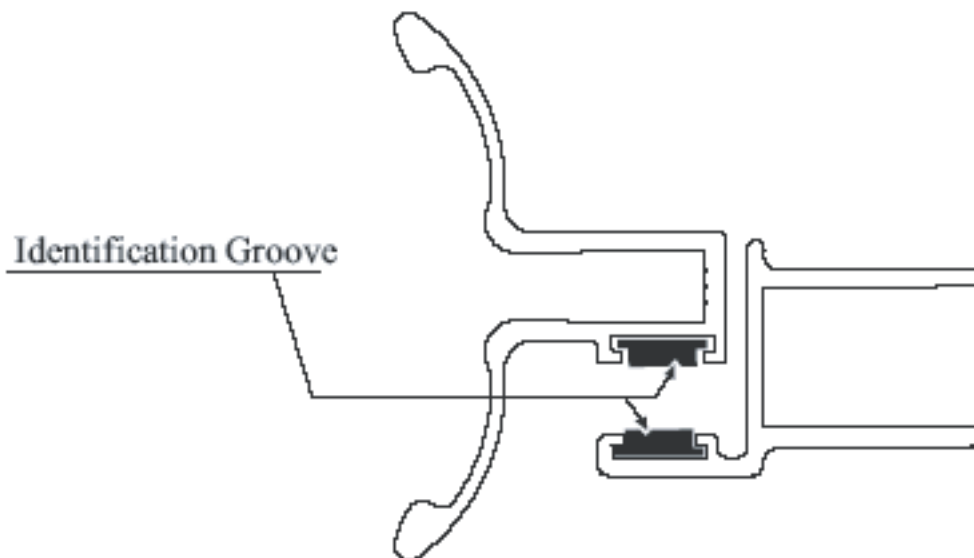

161 / 761 PARTS LIST

- | | | |
|------------------------------------|--------------------------------------|---|
| A. 3 Curb Sections (w/ weep slots) | L. 1 Clear Vinyl Jamb Seal | X. 2 Pivot Blocks |
| B. 4 135° Anchor Plates | M. 1 Pivot Jamb | Y. 1 Nylon Spacer |
| C. 48 #8 x 1/4" Truss Head Screws | N. 1 Strike Jamb (Magnetic) | AA. 2 Nylon Pivot Bushings |
| D. 3 Header Sections | P. 2 Snap-in Fillers | BB. 1 Security Washer |
| E. 2 Wall Jambs | R. 1 Glazed Door Panel | CC. 1 Door Handle Assy |
| F. 6 Plastic Wall Anchors | S. 1 Bottom Rail (see note) | DD. 1 Door Handle Vinyl (8") |
| G. 6 #8 x 1 1/2" Truss Head Screws | T. 1 Drip Rail | FF. 2 #6 x 3/8" Truss Head Screws |
| H. 4 Plastic Setting Blocks | U. 1 Roll Double Stick Tape | GG. 4 Rail End Caps |
| J. 2 Fixed Glass Panels | V. 1 Tapered Drip Vinyl | HH. 1 Basco Decal |
| K. 2 135° Posts | W. 2 #10 x 7/16" Sq. Head Set Screws | JJ. 8 Pcs. Vertical Glazing Vinyl (72") |
| | | KK. 4 Pcs. Horiz. Glazing Vinyl (72") |

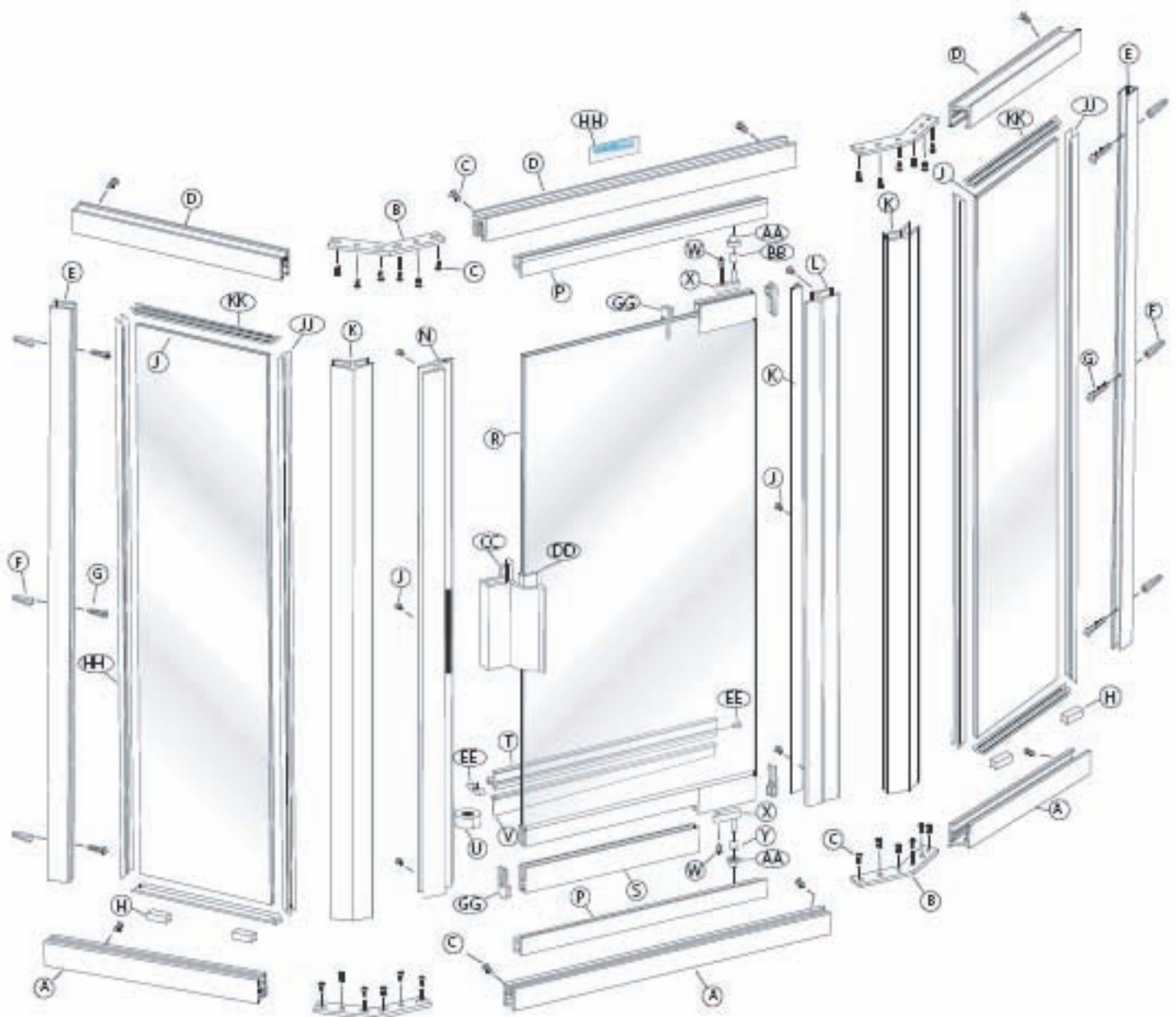

1 The BASCO 161/761 Thin-Line Shower Enclosure is completely reversible and may be installed pivot-left or pivot-right. For maximum waterproofing, the pivot jamb should be opposite the shower head. Use the diagram to determine the correct position for the door in your particular Thin-Line installation. This instruction sheet depicts a pivot-right installation.

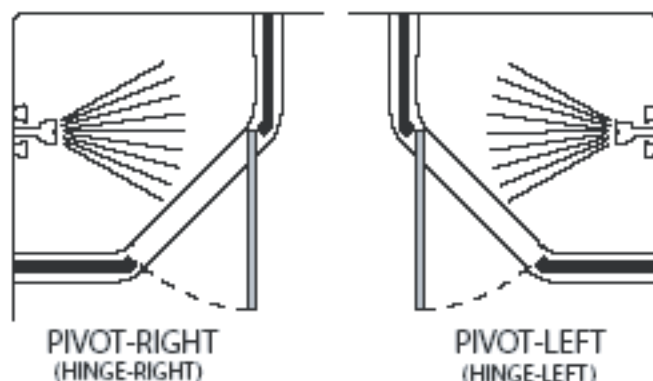

CAUTION: For safety reasons, the door panel must always open *outward*.

NOTE: If the header and curb are already assembled, proceed to step #3.

2 Assemble the three curb sections [A] (with weep slots) by sliding two 135° anchor plates [B] into the mitered ends and forcing the sections together. The weep slots in the curb must be to the inside. Using the slotted holes in the anchor plates as a guide, drill matching 1/8" holes into the curbs. Secure the anchor plates to the curb assembly with eight #8 x 1/4" truss head screws [C]. As you tighten the screws, be sure the mitered ends are forced tightly together. To increase the rigidity of the mitered joint, drill and install two more screws through the round holes in the bracket.

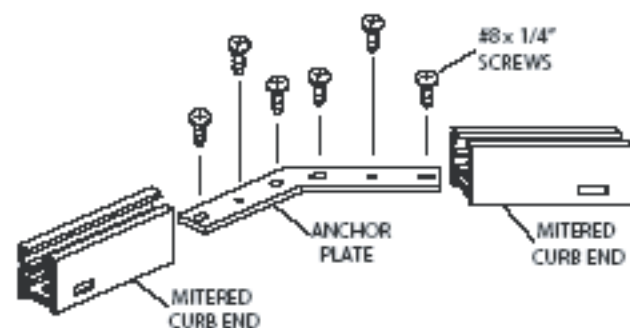

Assemble the three header sections [D] in the same manner and set the assembly aside.

3 The curb should sit near the centerline of the sill. If required, use a file to round the lower ends of the curb assembly to fit the shower sill properly.

Using a 3/16" drill bit, drill the interior face of the curb assembly on both ends as shown. These holes may be predrilled from the factory.

Reposition the curb assembly on the shower sill and mark its position with a pencil line along the interior and exterior base.

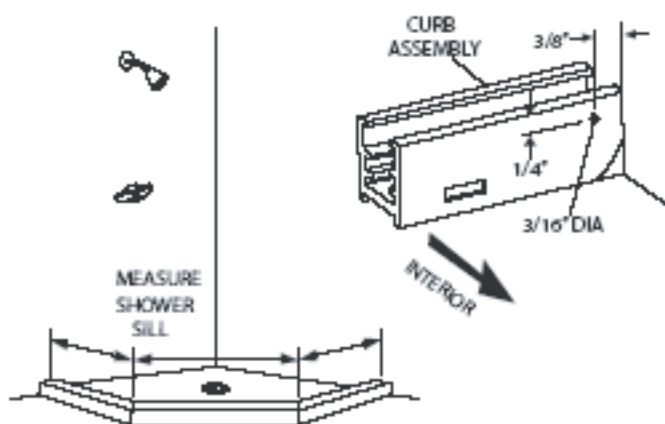

4

Place the two wall jambs [E] into the ends of the curb assembly [A]. Masking tape may be used to hold the curb in place during this operation. Plumb the jambs and mark the hole locations on the wall. Remove all parts and drill the walls for mounting hardware.

For tile or marble walls, drill six 3/16" diameter holes and insert the plastic wall anchors [F]. Attachments to fiberglass or acrylic units can be made in two ways. If reinforcement is built into the wall of unit, drill six 1/8" holes to install mounting screws directly into the reinforcement. If walls are not reinforced, drill six 3/16" holes and install plastic wall anchors or toggle bolts (toggle bolts not supplied by BASCO).

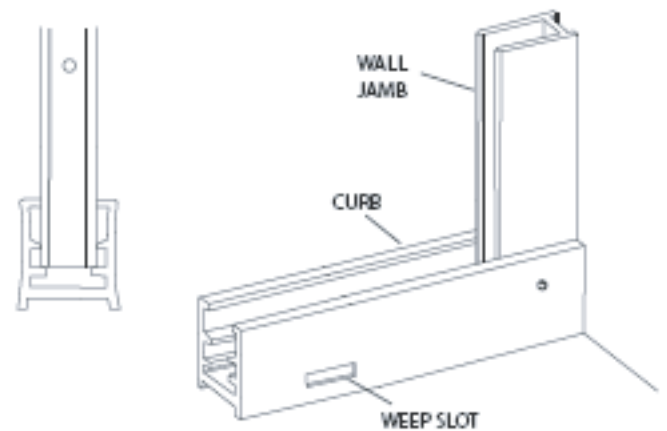

5

Wipe the shower walls and sill, curb assembly [A] and wall jambs [E] with a clean, dry cloth to remove any dust or debris. Apply a 1/4" bead of caulk along the inside of both of the pencil lines marked in Step #3. Carefully replace the curb in the exact position marked. Caulk the inside of the curb ends where they meet the wall. Caulk generously around the anchor plates [B], screws [C], and the inside of the mitered joints.

Replace both wall jamb and attach to the walls with six #8 x 1 1/2" truss head screws [G].

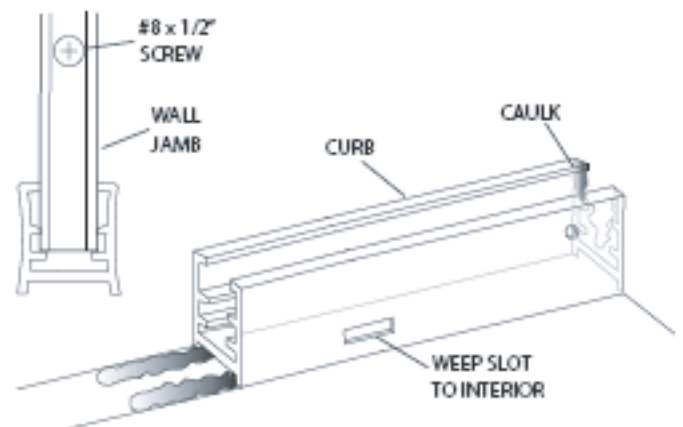

6

Place the setting blocks [H] in the curb assembly [A] as shown to support the two fixed glass panels [J]. Position the blocks 3" from the corner of the panels. Set the first glass panel into place on the setting blocks and approximately 1/2" into the wall jamb [E]. A strip of masking tape 1/2" from each vertical edge of the glass will aid alignment.

Press a 135° post [K] into the curb assembly. It should overlap the glass panel by 1/2". Use masking tape to hold the post in position temporarily. Repeat the glass and post installation on the opposite panel.

NOTE: To facilitate out of plumb walls, the 1/2" glass bite may be varied from 1/4" to 3/4".

NOTE: IF QUICK-N-STALL OPTION IS ORDERED, THE SETTING BLOCKS ARE NOT NEEDED.

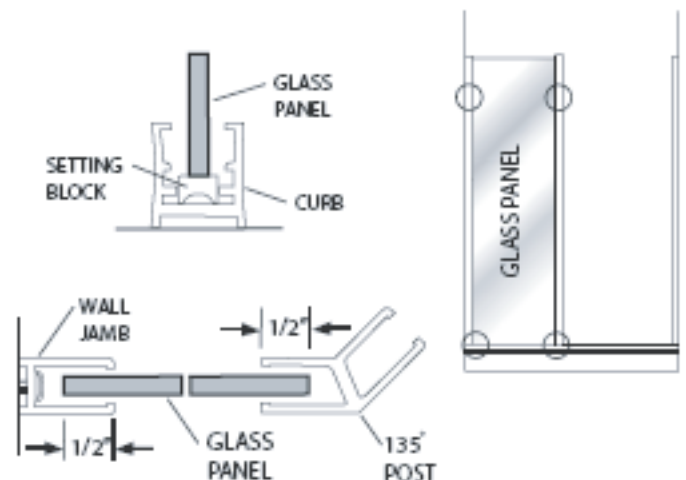

NOTE: Obscure or etched glass panels should be installed with the rough or patterned surface of the glass to the exterior of the unit.

7

Using a 3/16" drill bit, drill the interior face of the header assembly on both ends as shown. These holes may be predrilled from the factory.

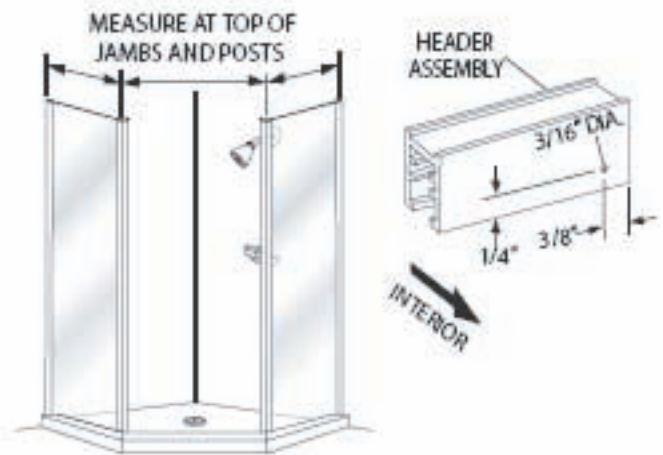

8

Press the header assembly [D] over the wall jambs [E] and 135° posts [K]. Check the posts for plumb. Adjust as required by varying the overlap of the header over the wall jambs. You may need to trim the ends of the header where it meets the wall. The minimum horizontal dimension for the door opening is the door panel width (see the graphic in Step #9) plus 1/2", maximum is the door panel width plus 1 3/4".

Using the holes in the ends of the header and curb as a guide, drill four 1/8" holes into the wall jambs. Drill four holes thru the header and curb into the two posts as shown, then enlarge the outer holes with a 3/16" drill for clearance on the self-tapping screws. Secure the header and curb to the wall jambs and posts with eight #8 x 1/4" truss head screws [C].

CAUTION: Slide glass panels [J] away from the jambs before drilling to prevent damage or breakage.

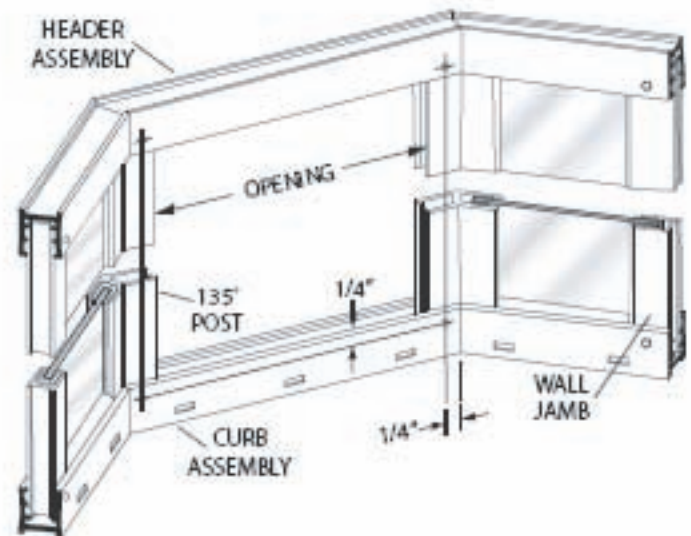

9

Slide the clear vinyl jamb seal [L] into the pivot jamb [M] and trim flush at both ends. The vinyl should be turned to trap water from the shower head. Secure the vinyl with a small quantity of glue or caulk at each end or by carefully crimping the vinyl pocket.

Press the pivot jamb and strike jamb assembly [N] (with magnetic strip) over the two 135° posts [K]. Refer to Step #1 for the proper handling of the door.

NOTE: The magnetic strip on the strike jamb must face the exterior and the clear vinyl jamb seal on the pivot jamb must face inward.

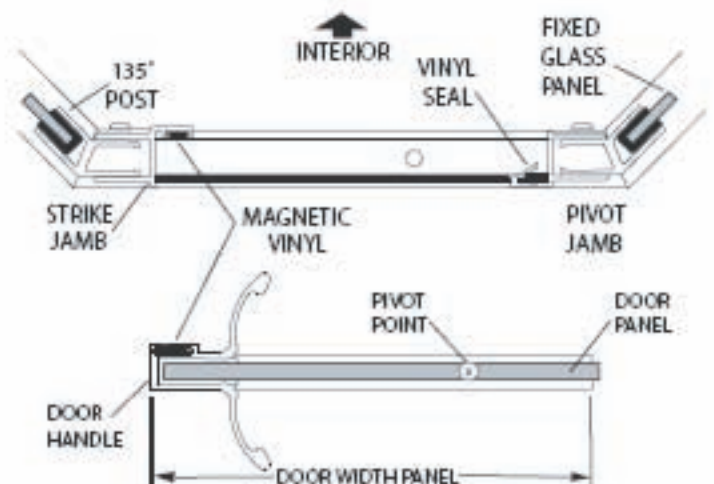

10

Snap the fillers [P] into the curb assembly [A] and header assembly [D] between the door jambs with the **RAISED LIP TO THE EXTERIOR** and the pivot holes toward the pivot jamb. Center the curb filler in the curb between the pivot and strike jamb (use masking tape to hold in position).

NOTE: The snap-in-fillers should be exactly $\frac{3}{8}$ " longer than the door panel width.

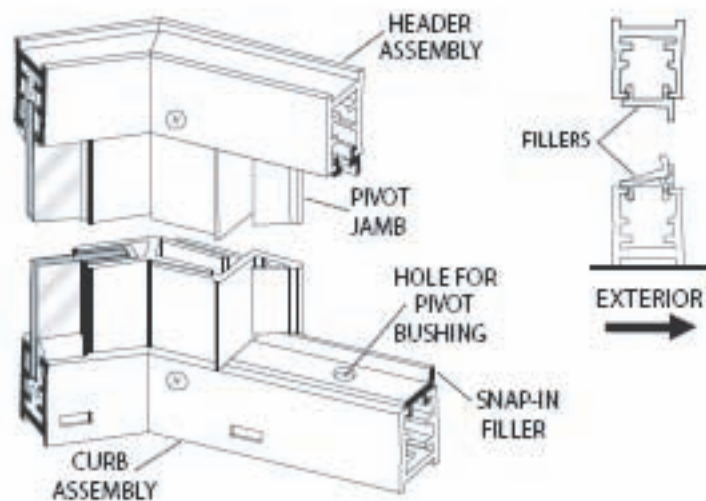

11

Pull the bottom end of the pivot jamb [M] tight to the curb filler [P] and plumb the jamb. Drill two $\frac{1}{8}$ " holes thru the pivot jamb and into the 135° post [K] in line with the screws in the head and curb and approximately $\frac{1}{4}$ " from the ends of the jamb. Drill a third hole centered between the first two, then enlarge the outer holes with a $\frac{3}{16}$ " drill for clearance on the self-tapping screws. Attach the pivot jamb permanently with three #8 x $\frac{1}{4}$ " truss head screws [C].

Slide the header filler [P] tight against the pivot jamb. Push the strike jamb [N] tight against the fillers top and bottom. With the pivot jamb plumb and both fillers tight between the two door jambs, the strike jamb also will be plumb and parallel to the pivot jamb. Attach the strike jamb to the other 135° post [K] in the same manner as the pivot jamb.

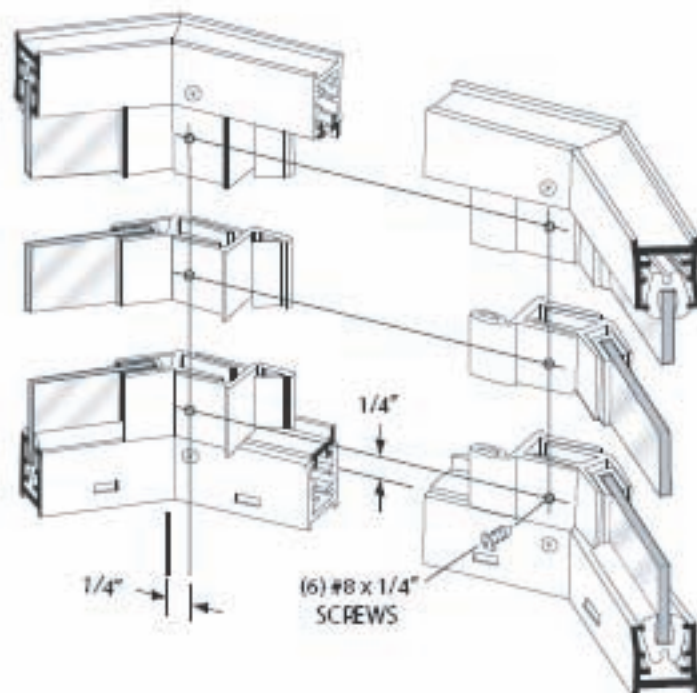

12

NOTE: Obscure or etched glass doors should be installed with the rough or patterned surface of the glass to the exterior of the unit.

Determine which end will be the bottom. Using a mallet or a hammer and a block wood block (never a hammer alone), carefully drive the bottom rail [S] over the bottom edge of the glass and vinyl, (spraying glass cleaner or water onto the vinyl will make assembly easier) snug to the factory installed rail. Both rails should be set back $\frac{1}{8}$ " from the pivot edge of the door and the bottom rail should end $\frac{1}{8}$ " from the strike edge. Trim the excess vinyl even with the ends of the rails.

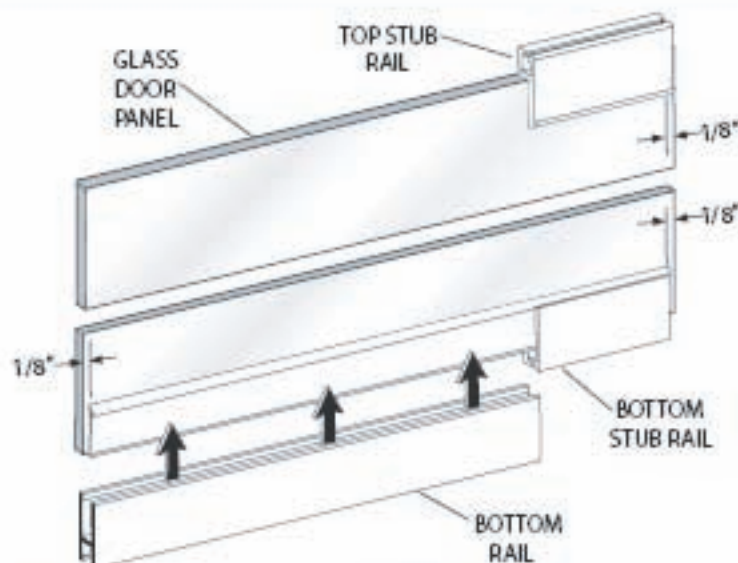

13

Thread the two #10-24 x 7/16" square head set screws [W] into the tapped holes in the pivot blocks [X] (pivot blocks may be pre-assembled). Slide the pivot blocks into the top and bottom rails of the glazed door panel [R] with the stainless steel pins toward the pivot side of the door (see detail).

Position the pivot pins 1 5/8" from the pivot edge of the door panel. Tighten the set screws just enough to prevent the pivot blocks from moving (finger tight plus a quarter turn). A 3/16" wrench (not supplied by BASCO) will fit the set screw heads.

Press the white nylon spacer [Y] over the bottom pivot pin on the door panel.

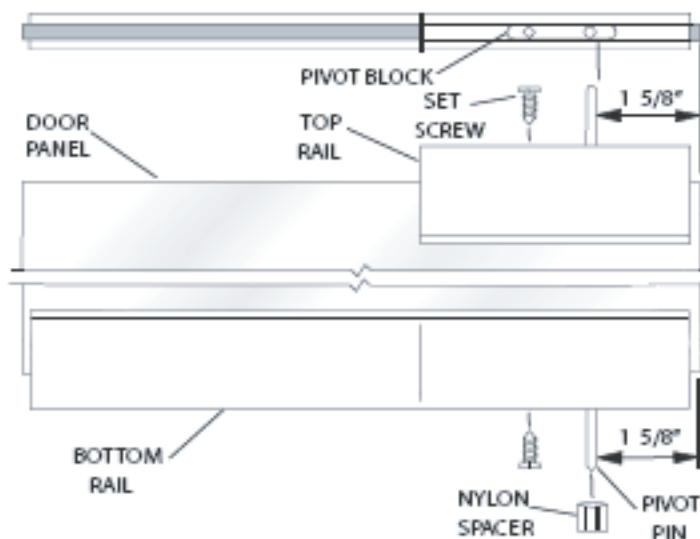

14

Insert the two nylon pivot bushings [AA] into the pivot holes in the head and curb fillers [P].

Lift the door panel [R] and insert the top pivot pin into the pivot bushing in the header filler. Hold the door vertical and insert the bottom pivot pin into the pivot bushing in the curb filler. It may be necessary to remove the header retaining the screws and raise the header slightly to install the door.

When the door has been set into place, snap the security washer [BB] over the top pivot pin to hold the upper pivot bushing in place and prevent accidental dislodging of the door.

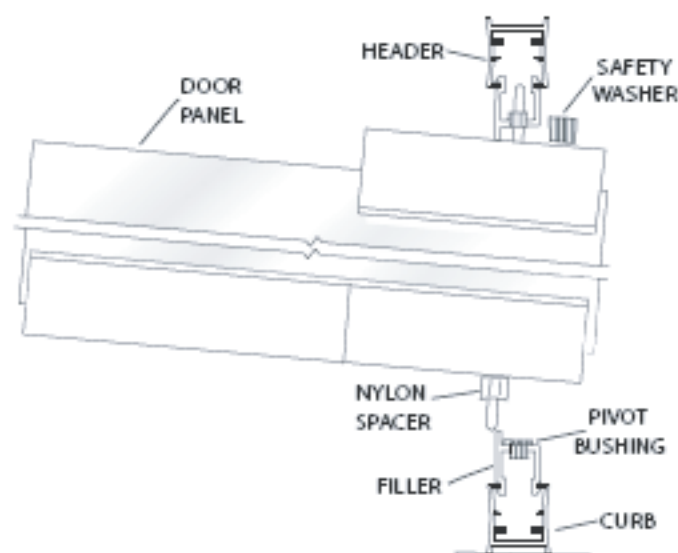

15

Slide the door handle [CC] with magnet onto the strike edge of the door panel [R]. Close the door and slide the handle up or down until the two magnetic strips are aligned. Use a pencil or masking tape to mark the top and bottom edges of the door handle on the door.

Slip the door handle vinyl [DD] over the door between the marks and carefully drive the door handle onto the door panel. (DO NOT USE A METAL HAMMER). Spraying glass cleaner or water onto the vinyl and handle will make assembly easier.

Close the door and check the clearance with the strike jamb. If necessary, loosen the set screws [W] on the top and bottom pivot blocks [X] and adjust the door panel to align the strike magnets. When the door panel is properly aligned, tighten the set screws securely.

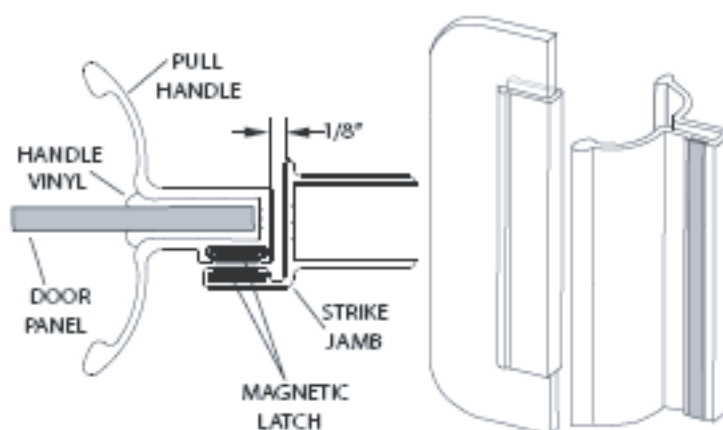

16

Clean the interior face of the bottom door rail and the flat side of the drip rail thoroughly with rubbing alcohol to ensure proper adhesion of the double stick tape [U]. Unroll the tape and carefully attach it to the back of the drip rail (do not peel the tape backing yet).

Insert the tapered drip vinyl [V] into the drip rail. Position the drip rail flush with the bottom and pivot side of the bottom door rail, then raise the strike side until the bottom edge of the drip vinyl is parallel to the bottom of the door. Mark the location of each end of the drip rail.

NOTE: Cleaners with alcohol content can dissolve the adhesion that attaches the drip rail. To prevent this possibility, place a small bead of clear sealant at the top of the drip rail where it is attached to the bottom rail.

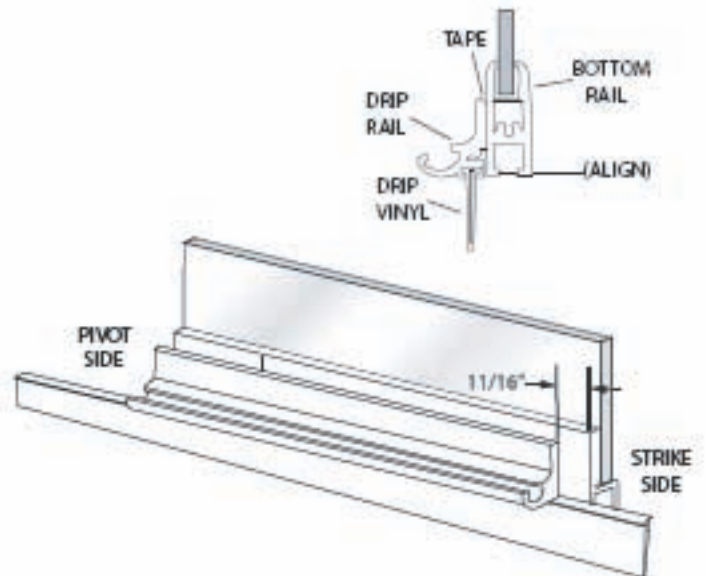

17

Adjust the drip vinyl [V] by sliding it left or right until it almost touches the curb. Trim the vinyl (flush with the pivot end and notch 1/2" longer than the drip rail as shown on the strike end). Secure it with one #6 x 3/8" truss head screw [FF] in the pivot end of the drip rail [T].

The drip plug [EE] is supplied with a left and right hand plug together. Break the right and left drip plug apart and insert the appropriate plug into the high (strike) side of the drip rail. Discard the unused drip plug. Peel off the tape backing and carefully press the drip rail to the door in the marked position.

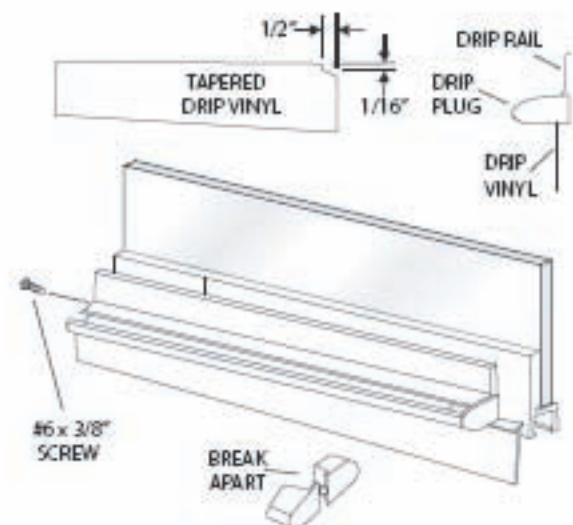

18

Press the four rail end caps [GG] into the ends of the top and bottom door rails.

NOTE: Do not use a metal hammer to install the end caps.

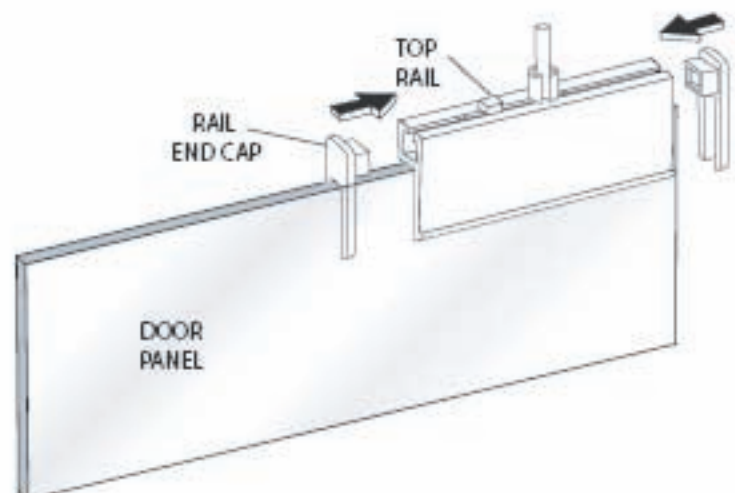



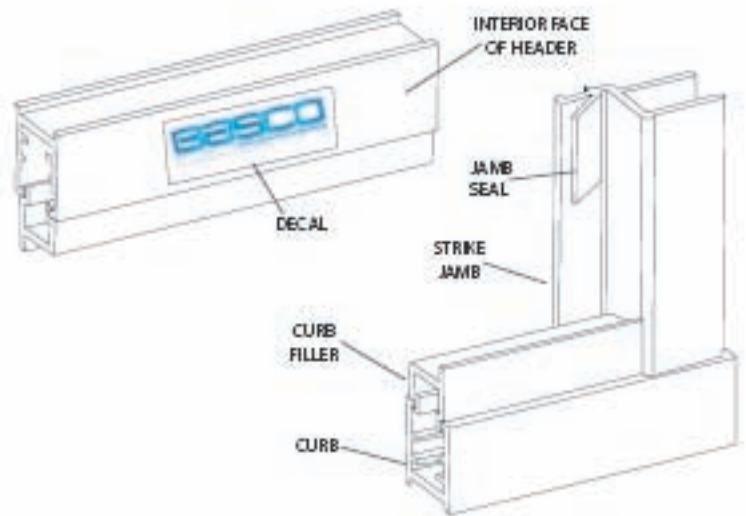

19

Peel off the backing on the BASCO decal [HH] and apply to the inside surface of the header. Trim the flap on the clear vinyl strike jamb seal to clear the bottom door rail.



20

Inspect the pieces of black glazing vinyl, and note the two different profiles. The smaller shape [JJ] is installed vertically and the larger shape [KK] is installed horizontally. For structural strength and maximum water resistance, these vinyls are designed to fit tightly between the glass and framing. To speed installation, use glass cleaner for lubrication and a small block of wood to press the vinyl into place.

FIXED GLASS PANEL	VERTICAL	HORIZONTAL
1/4" GLASS REQUIRES :	V-219 	V-220 
3/16" GLASS REQUIRES :	V-226 NOTCH 	V-225 NOTCH 

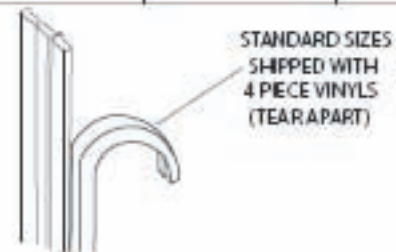

21

Cut eight pieces of the smaller vinyl [JJ] 1" longer than the vertical opening (to prevent gapping from shrinkage) and trim the ends on a 45° angle. Using the masking tape guides, center the first glass panel [J] in the frame. Cut four short (1" - 2") pieces of the small vinyl and press into the jamb and post on each side to hold the glass temporarily.

Take one of the long pieces of vinyl, and starting on the outside exterior jamb, press each end into the frame and work toward the middle. Be careful not to stretch the vinyl. Install the other three pieces in a similar fashion.

Repeat for the second glass panel.

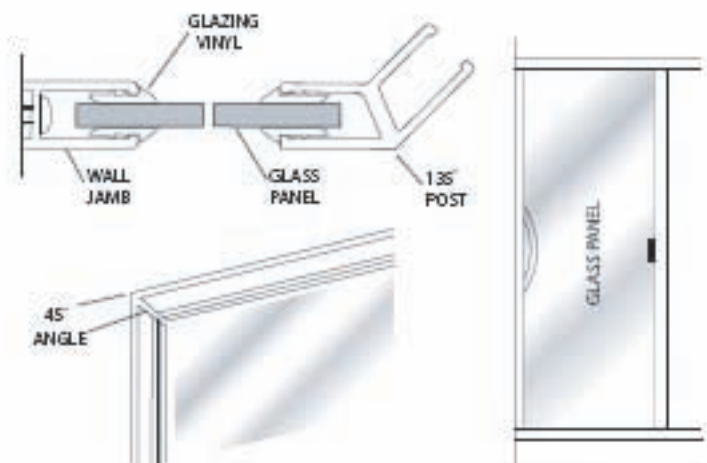

22

Cut eight pieces of the larger vinyl [KK] 1/2" longer than the horizontal opening and trim the ends on a 45° angle. Install the top exterior vinyl starting at both ends and working toward the middle. Be careful not to stretch the vinyl.

Install the top interior vinyl and the two bottom vinyls in the same way.

Repeat for the second glass panel.

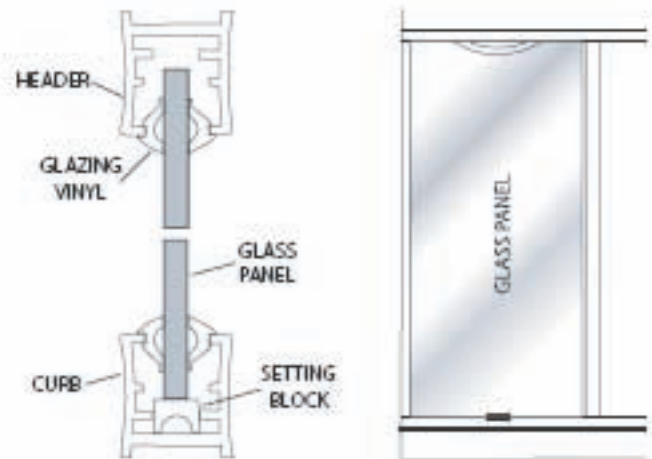

23

Carefully caulk the interior jamb-to-wall and curb-to-base joints. For appearance, you may wish to caulk the exterior joints as well. We recommend you wait twenty-four hours before the first shower to allow the caulking to cure properly.



Note: Do not caulk over weep holes