



INSTALLATION INSTRUCTIONS

1927 PRECERIA CURVED FRAMELESS SHOWER ENCLOSURE



1927 - Preceria Parts List

KEY	DESCRIPTION	PART NO.	QTY
A	HEADER LEFT (FP1927L-74)	SC885-11-72	1 *
A	HEADER RIGHT (FP1927R-74)	SC885-12-72	1 *
A	HEADER MIDDLE (FP1927M-74)	SC885-01-62	1 *
S1	HEADER PIN	SC4014	2
B1	U-CHANNEL	SCX887 (71 1/4)	1
B2	U-CHANNEL	SCX887 (73 1/4)	1
B3	U-CHANNEL	SCX887 (34)	1
D	DRIP VINYL	SCV452-1-28	1
D1	BULB SEAL VINYL 98"	SCV927	2

-	PRECERIA UNIT PARTS PAK	SCPRCR1PP	1
N	HEADER CORNER BRACKET ASSEMBLY	SC4061	2
O	HEADER BRACKET ASSEMBLY	SC4062	2
S	HEADER PIN	SC4015	4
R	HUB	SC4027	4
Q	7/16" SET SCREW	SCR62SV	4
P	HOLE PLUG	SC4028	4
U	CORNER VINYL	SCV4022	2
T	5mm ALLEN WRENCH (BALL END)	SC5219	1
T1	10-24 X 3/4 PAN CROSS HEAD SCREW	SCR63SV	1
Z	PRECERIA LOGO	PREC-NP	1

NOTE: Not every part in parts pak will be used

-	PRECERIA FASTENERS PARTS PAK	SCPRCR2PP	1
V	WALL PLUG	SC4106	16
W	ALCOHOL PAD		2
X	#8 X 1 1/2 SCREW	SCR09SV	16
Y1	1/4 SETTING BLOCK	SC8165	10
Y2	3/8 SETTING WEDGE	SCV926	6
Y3	1/8 SETTING BLOCK	SCV925	8
Y4	1/16 SETTING BLOCK	SCV924	8

NOTE: Not every part in parts pak will be used

C	162 HINGE	HG16A162	2
H	8" HANDLE	SC4017	1

GLASS PANELS			
G1	DOOR PANEL	CLB2800-14	1
G2	SIDE PANEL		1
G3	SIDE PANEL W/HINGE NOTCH		1

* Depending on the configuration for your application, one of the three headers listed will be provided.

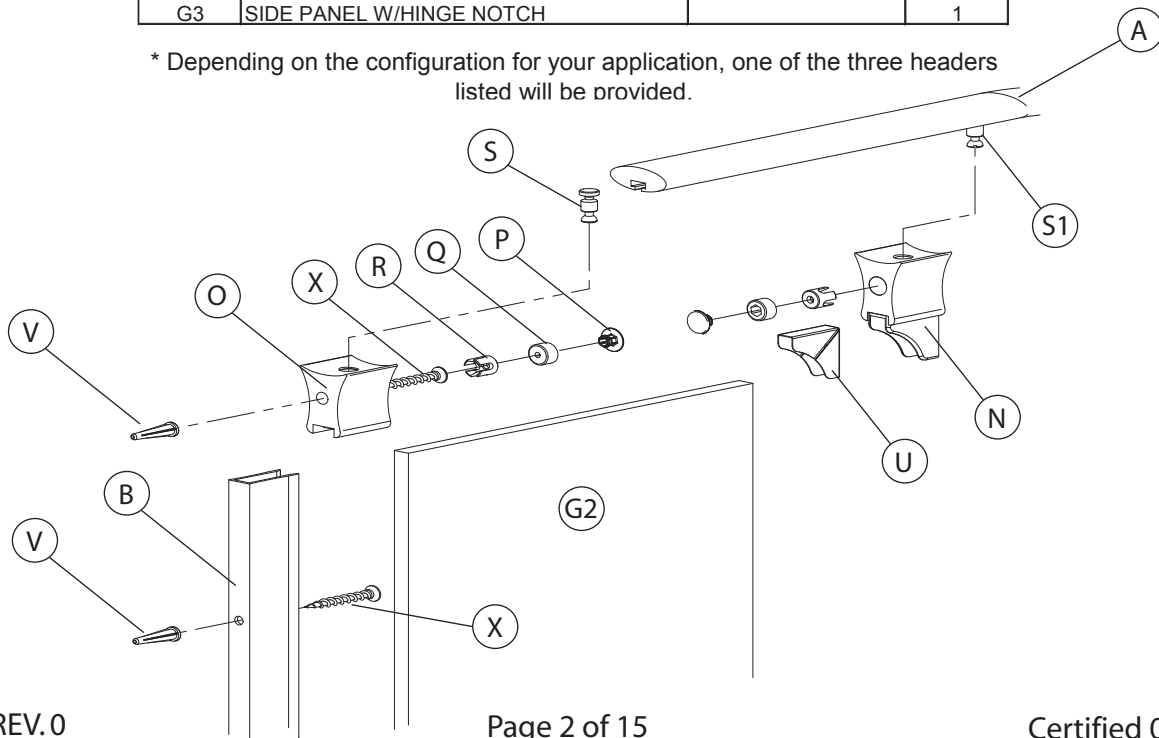

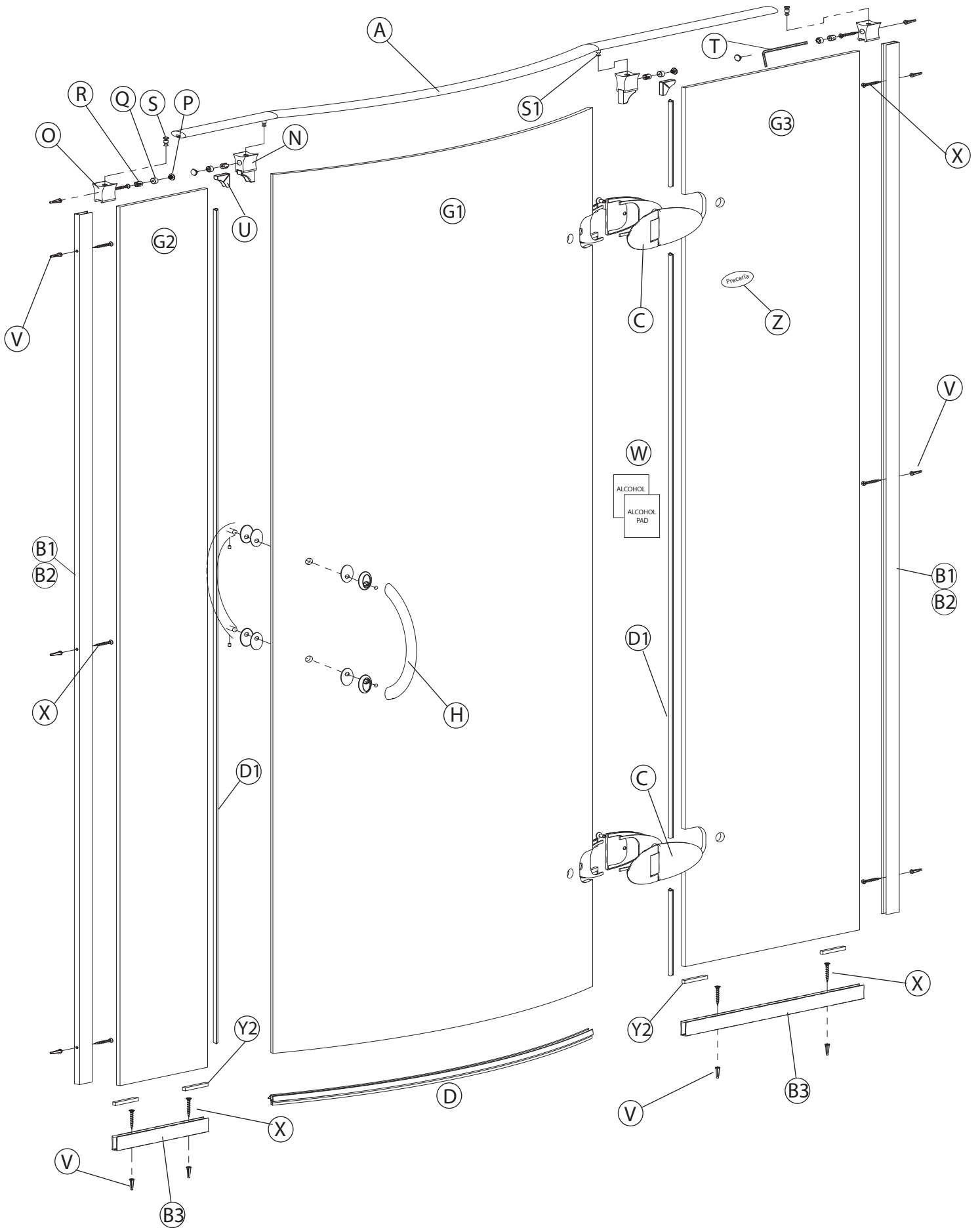

Tools:

To install your Basco Shower Enclosure, you will need the following:

- Pencil
- Low Tack Masking Tape
- Tape Measure
- 4 ft & 6 ft Level
- #2 Phillips Screwdriver
- Drill
- 3/16" - 1/4" Drill Bit
- Hack Saw
- Caulking (Clear Silicon Recommended)
- Caulking Gun
- Suction Cups
- Center Punch (if drilling into tile)
- Files

Installation Notes:

Unpack your unit carefully and inspect for freight damage. Lay out and identify all parts using instruction sheet as a reference. Before discarding the carton, check to see that no small hardware parts have fallen to the bottom of the box. If any parts are damaged or missing, refer to the description noted in the instructions when contacting your dealer for replacements.

Handle the glass panels carefully and protect the edge. Safety tempered glass is very resistant to breakage, but the sharp corners of the panels can damage tile and flooring surface. Although safety tempered glass is very resistant to breakage, the glass can still break if unequal pressure is applied during installation.

Please wear safety glasses whenever drilling or cutting. When drilling holes in ceramic tile or marble, use a center punch and hammer to carefully break the glazed surface, this will prevent skidding when drilling.

Maintenance:

Two primary materials are used to manufacture your new Basco shower enclosure: tempered glass and anodized aluminum. To assure a long lasting finish on the enclosure, wipe it down with a towel after each use.

For occasional, more concentrated cleaning efforts, we find that **Comet Non-Abrasive Bathroom Cleaner** works extremely well. Be sure that any over spray falling on the aluminum frame is rinsed thoroughly and dried. Many over-the-counter cleaners, if applied to the aluminum and left on, will harm the metal finish and cause permanent damage, even though their directions indicate safe use on shower doors. Never use a scouring agent to clean the aluminum.

NOTE: Tempered glass cannot be cut.

1 Mark a continuous centerline position on the threshold if it does not exist from the original measuring process prior to ordering (Ref. to Preceria Curved Threshold Measuring Guide, located at www.bascoshoweroor.com). Next mark your centerline position on the wall using a level which is in-line with the threshold centerline.

Note: Centerline - is a term used to determine the exact position of the unit after being installed.

a - Left Opening Panel Width (From Wall to Edge of Glass)
 b - Right Opening Panel Width (From Wall to Edge of Glass)

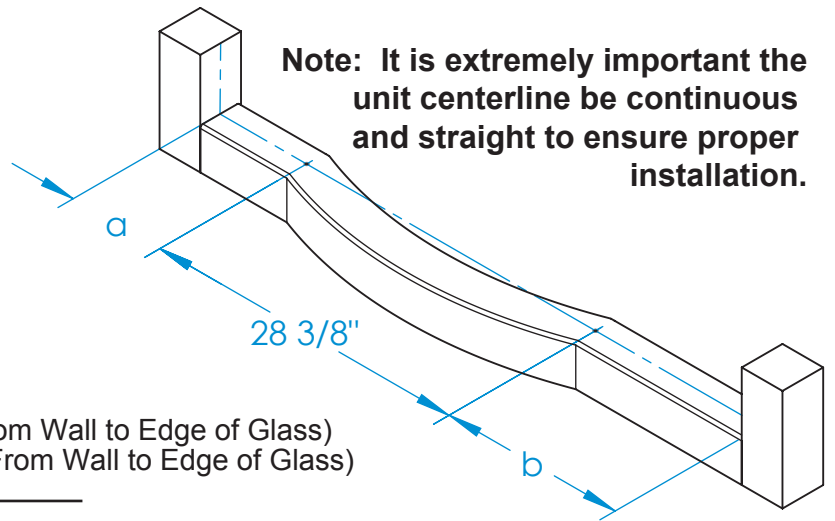

2 Check the threshold for out of level conditions. If no out of level conditions exist, measure up each wall centerline a distance of 73" and clearly mark the location and drill 3/16" hole for securing header bracket [O]. (See example)

If out of level conditions exist, measure up wall centerline, on the "high" side of the threshold, a distance of 73" and clearly mark the location. For the wall centerline distance on the "low" side of the threshold, determine the threshold out of level distance and add this to 73". Measure this distance up the wall centerline and clearly mark this location. Once marked, drill 3/16" holes for securing header brackets [O].

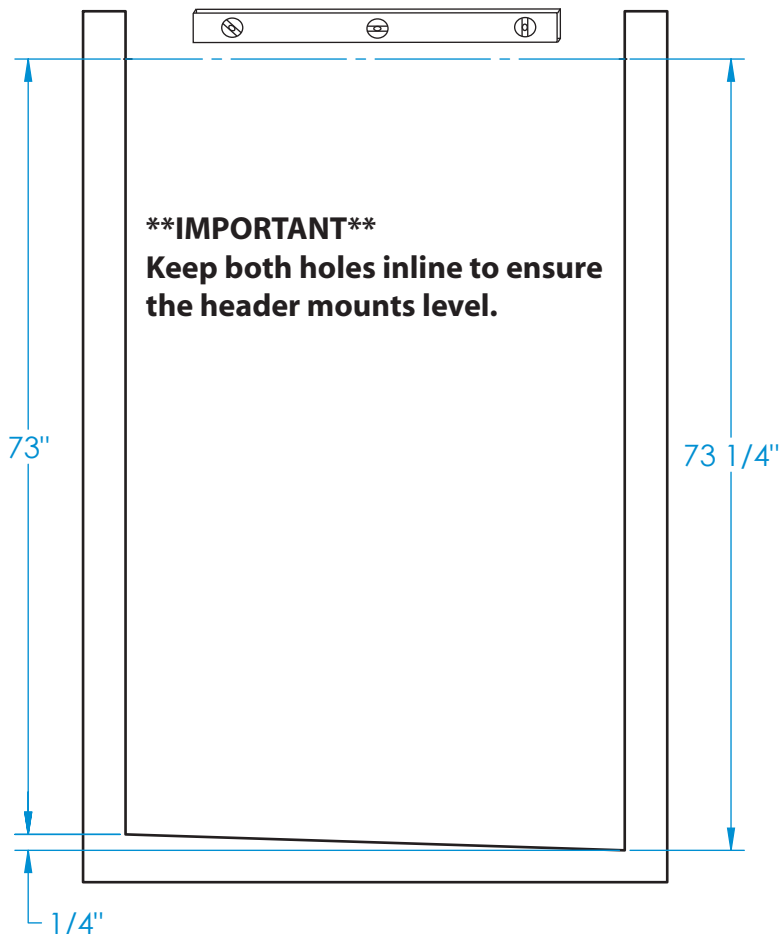
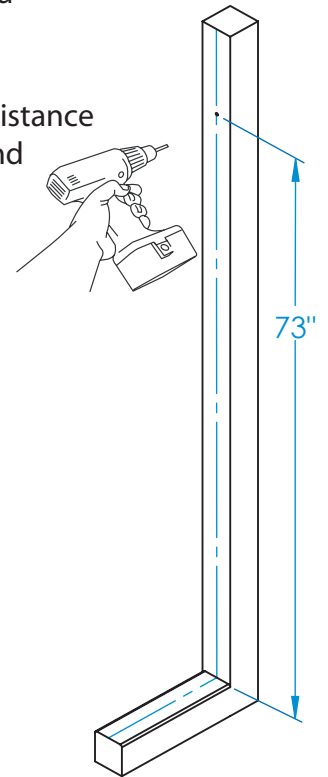

3 Using U-channel [B3] of length 34", cut two pieces to the appropriate sizes. Each piece will be equal to its respective panel width referenced in Step 1 ("a" and "b"). If your unit was ordered with a notch panel, please see appendix "A" for additional information.

Next drill two 3/16" holes located approx. 2-1/2" from each end of the u-channel [B]. Place the centerline of the u-channel over the centerline of the threshold. With a pencil mark the hole position on the threshold. Remove the u-channel and drill 3/16" into the threshold in the marked positions.

Note:
Distance between u-channels should be 28-3/8"
It is critical that the threshold U-channels are centered on the centerline and in line with one another.

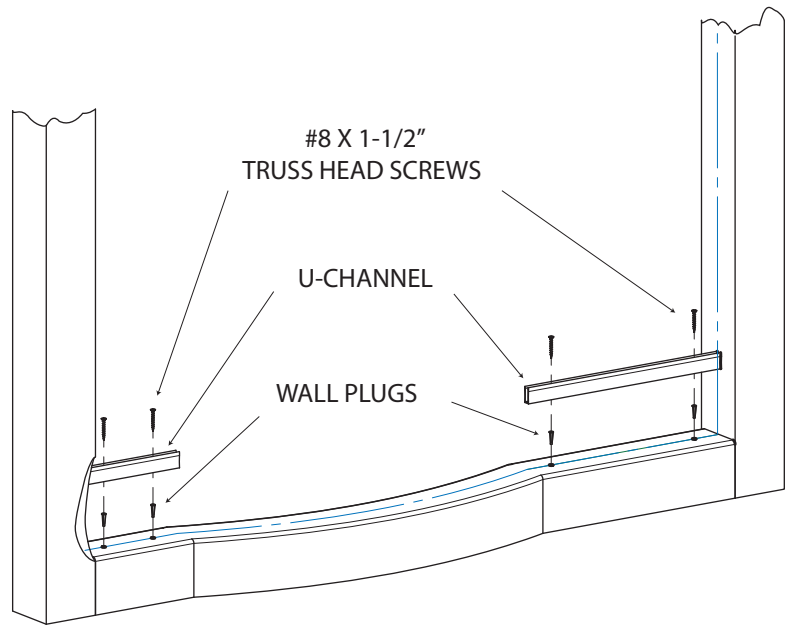

4 Insert a small amount of silicon into each hole, then insert a wall plug [V] in each hole. (Note: This must be done just before u-channel installation.) Then carefully cut heads off wall plugs [V] with a razor blade. Place each u-channel in correct position and secure each piece of u-channel [B] with #8 x 1-1/2" truss head screws [X].

Note: Do not overtighten screws or may begin to deform u-channel [B] opening.

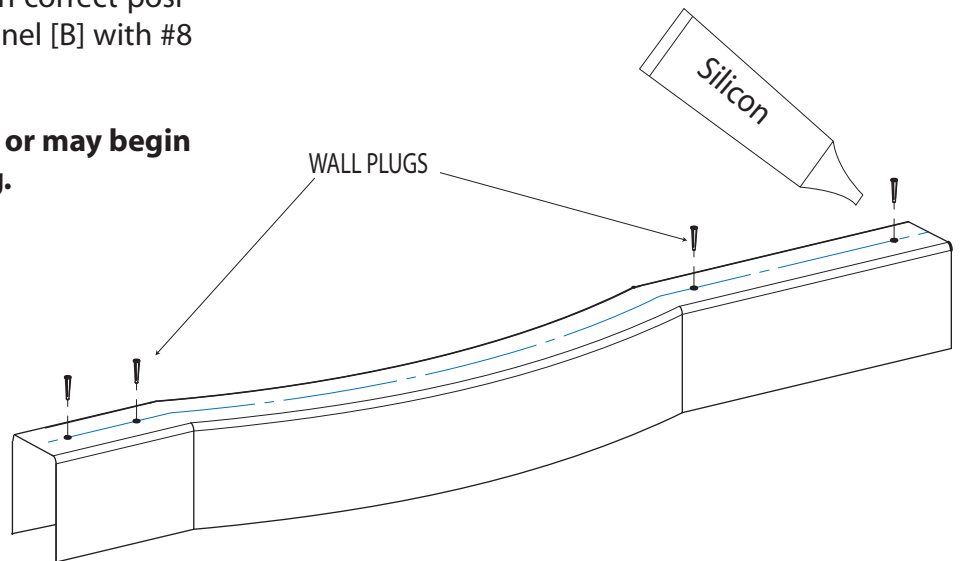

5 Using the u-channel [B1/B2] of lengths 71-1/4" & 73-1/4". Place the u-channel [B1] of length 71-1/4" on the higher wall. Cut the second piece of u-channel [B2] according to the out of level conditions (See Picture).

If no out of level conditions are present, cut piece to 71-1/4". Next drill three 3/16" holes in each piece of u-channel [B], one approx. 3" from each end and one in the middle of the u-channel [B].

Place u-channel [B] center line over the wall center-line. Mark hole locations with a pencil. Remove the u-channel [B] and drill 3/16" holes in each marker location.

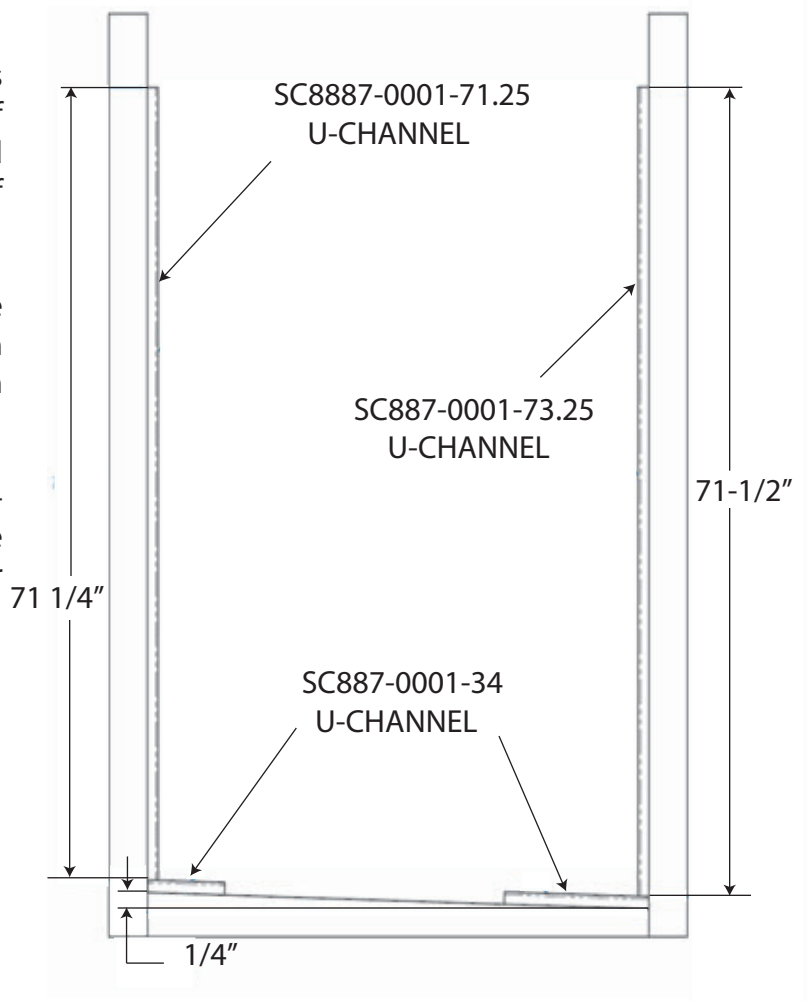

6 Place a small amount of silicon into each hole and insert a wall plug [V]. (Note: This must be done just before u-channel installation.) Then carefully cut heads off wall plugs [V] with a razor blade. Place u-channel [B] in correct position and secure each piece of u-channel [B] with #8 x 1-1/2" truss head screws [X].

Note: Do not overtighten screws or may begin to deform u-channel [B] opening.

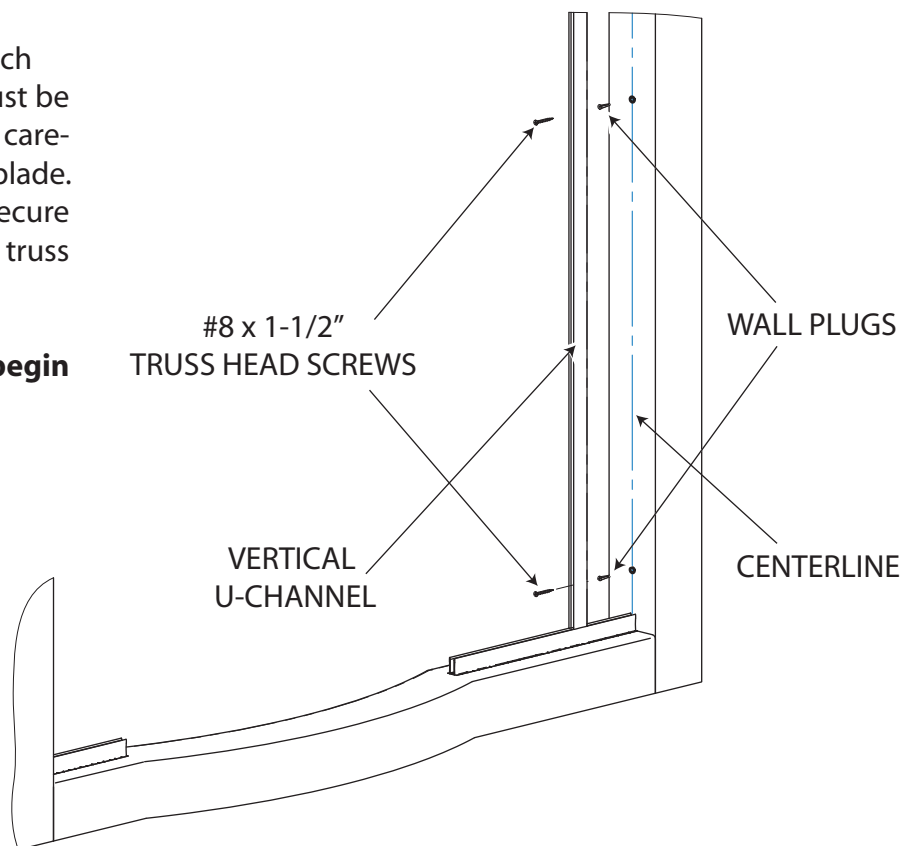

7 Using suction cups slide the two side panels of glass [G2/G3] into the appropriate side. Use setting block and setting wedge to make exposed edges of glass level and plumb. Exposed edges **MUST** be level and plumb before moving to next step.

Place setting wedges at the open ends (door opening) of the u-channels and place 1/4" setting blocks as shown or approximately every 18". **DO NOT** place setting blocks over screw heads.

Different size setting blocks may be required depending on level conditions. Various size setting blocks are provided.

Note: The glass should be approx. 1/16" lower than the top of the wall u-channels.

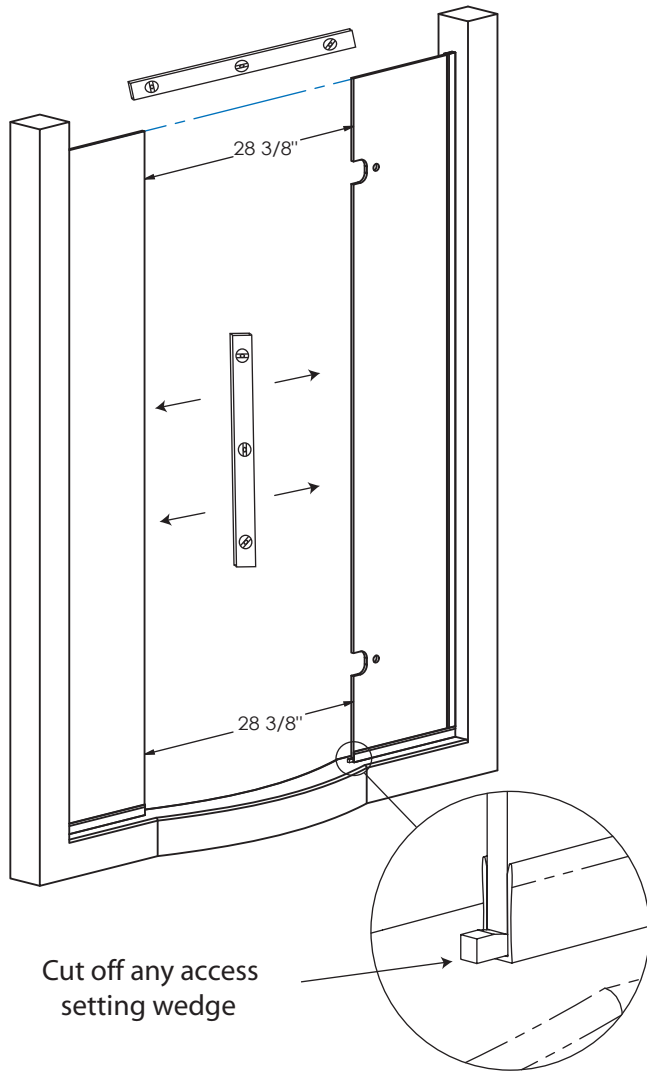
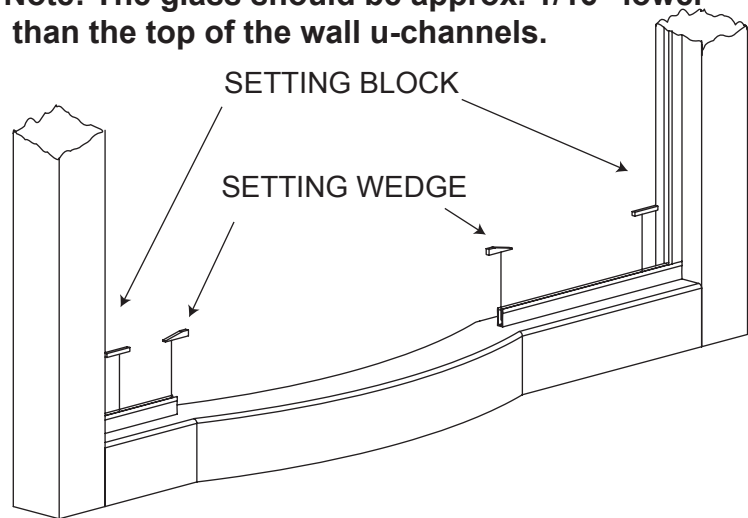

8 Cut the header [A] to the opening size. Measure each panel width at the top of unit (edge of glass to wall), and add 1/16" to each end. Record these measurements and their location (left or right). Now place the corner header brackets [N] over the header pins. Measure from the inside of the header bracket [N] and cut at the predetermined length from the calculation above.

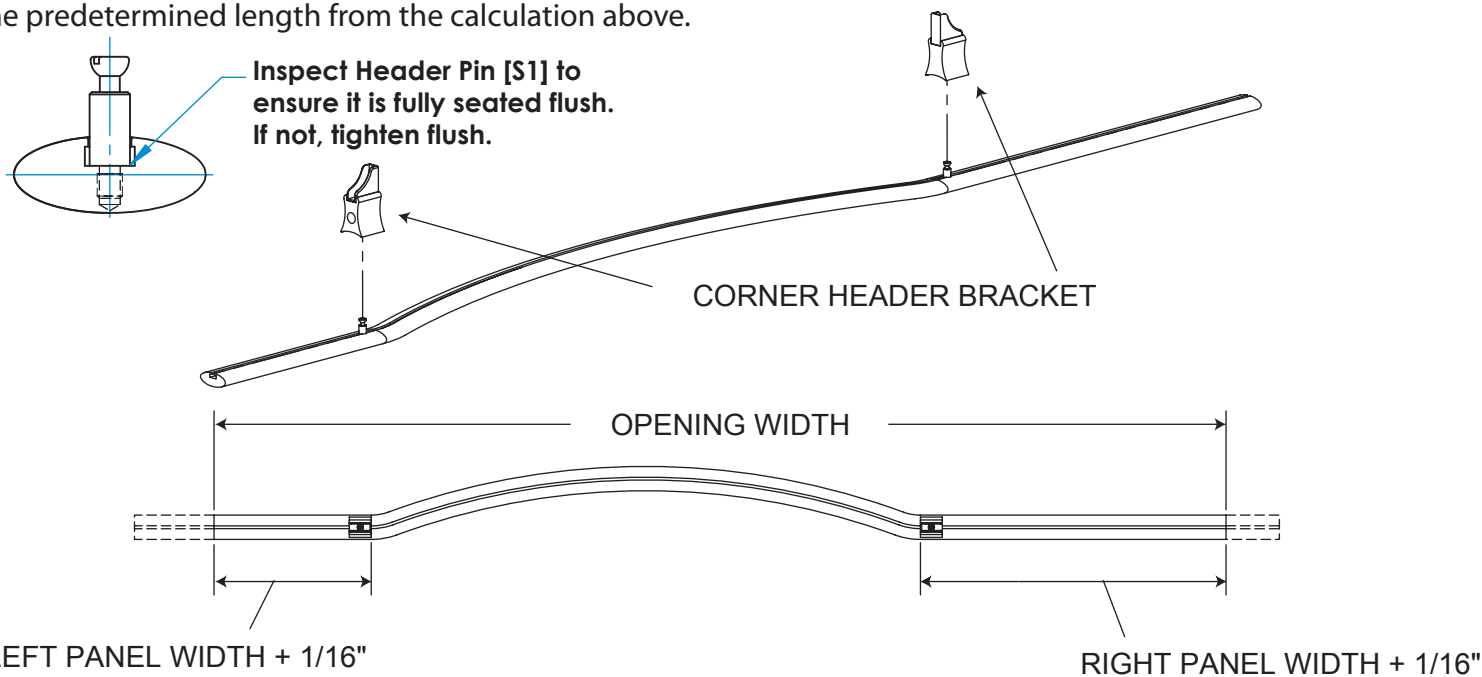

Take both header brackets [O] and drill 3/16" hole completely through the end. Next put a wall plug [V] into the hole that was drilled in the wall, and silicon the wall plug [V]. Then carefully cut heads off wall plugs. Place the header bracket [N] back onto the vertical u-channel [B] and screw into the wall with the #8 x 1-1/2" set screws [X]. Repeat this process on each side of enclosure.

Note: Place part of the unit box over the glass when attaching the header bracket.
Be sure not to damage set screw threads while drilling bracket.

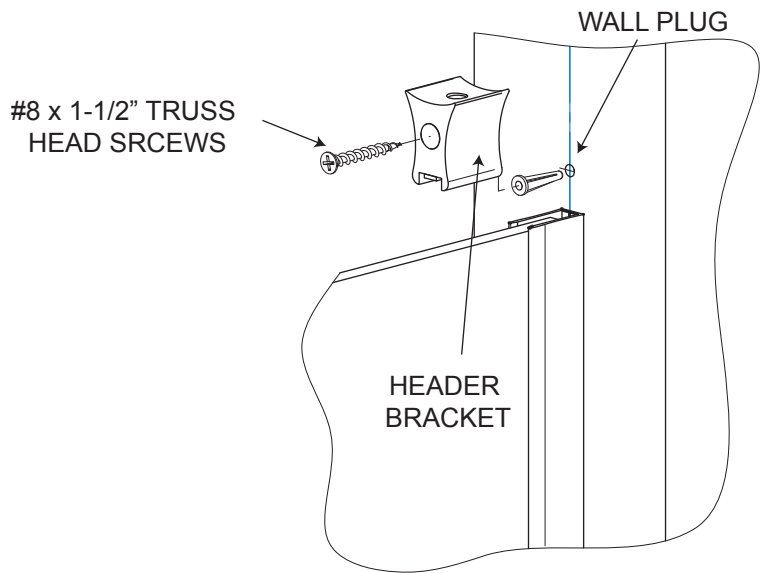

9 Place the corner vinyl [U] on the exposed corners of the glass. Now place the corner header brackets [N] over the corner vinyl [U].

Option 2: Attach header brackets [N] to header [A] prior to mounting on glass.

Option 1: Attach header brackets [N] to glass as shown.

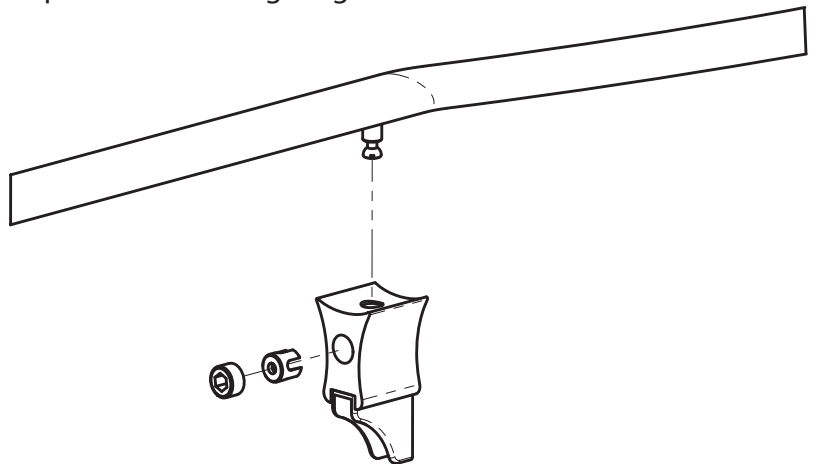
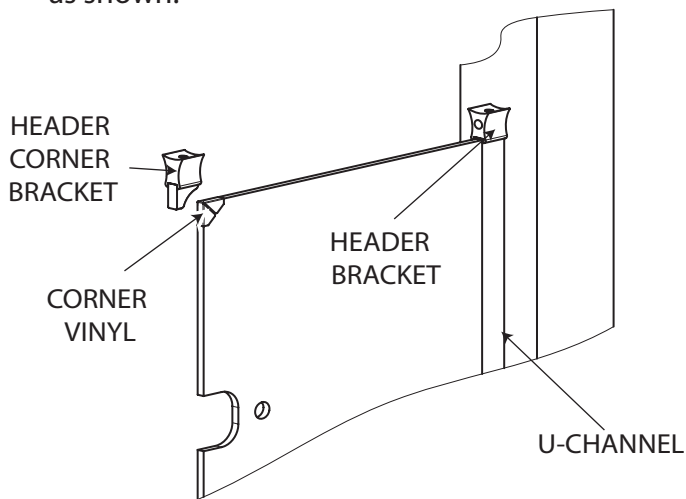

NOTE: If there is any exposed vinyl after installing the brackets carefully trim it off with a razor blade.

10 Slide one header pin [S] into each end of the header [A]. Line up the pins with the appropriate header bracket [N/O]. Drop the header pins [S] into the header brackets [N/O].

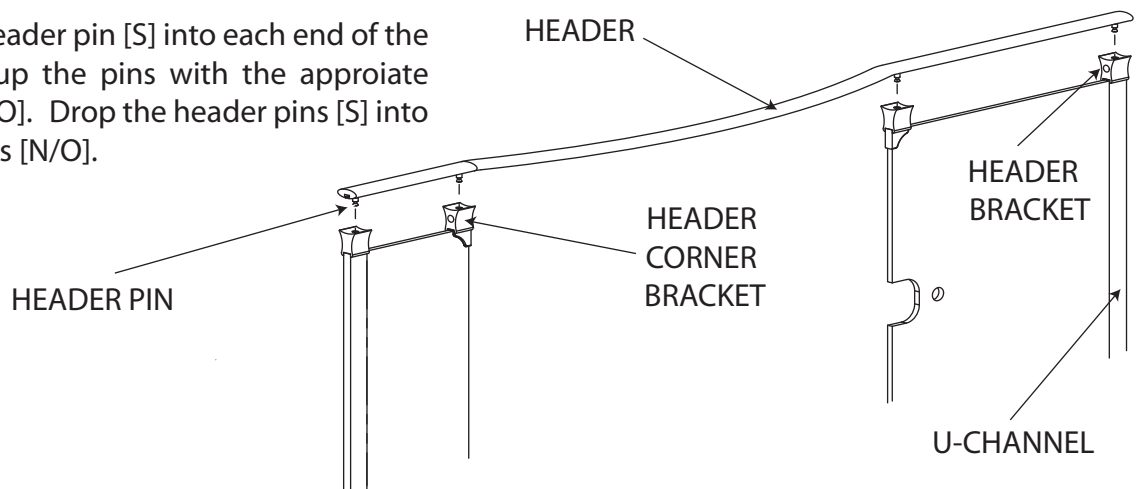

11 When aligning the header pins [S/S1], with the header [A], make sure the header [A] is seated flush against the header brackets [N/O]. Improper alignment will prevent fasteners from tightening easily in following step.

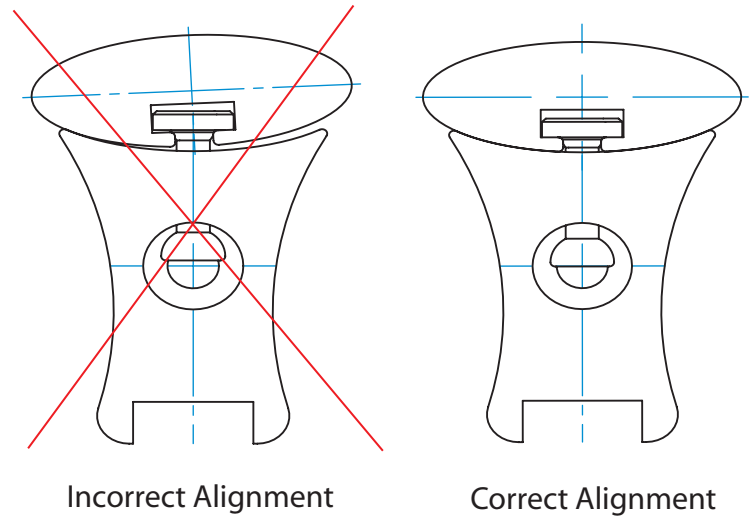

12 Place the four hubs [R] into each header bracket [N/O]. The open side of the hub [R] **MUST BE** facing up and the header should be seated before tightening. If the hub [R] does not “bite”, it may be necessary to push it deeper in the bore with a screw driver.

Note: To remove hub, use a #10-24 x 3/4 screw from the parts pak.

The space between the hub forks should be facing up

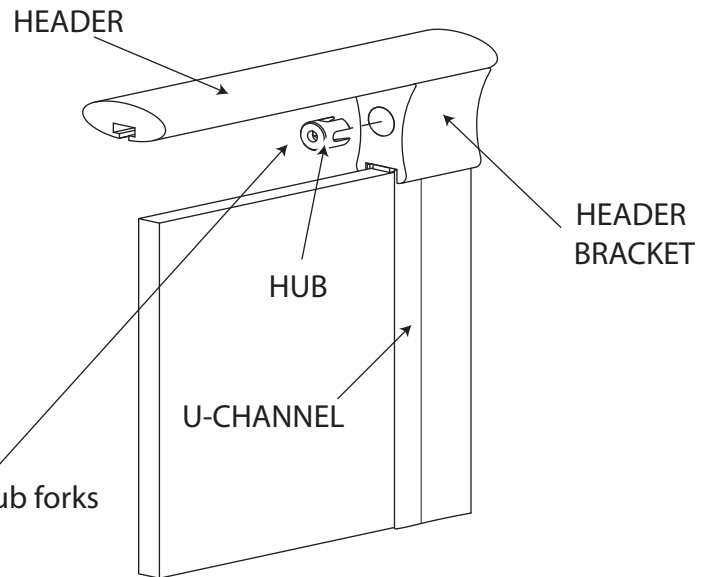

13 After getting the hubs [R] in the correct position insert the set screws [Q] into the hole. The set screws [Q] can be tightened with the allen wrench [T] provided. **DO NOT** install hole plugs [P] at this time.

Note: Begin threading set screw [Q] by hand, then tighten with ball end of wrench.

Note: Make sure not to scratch glass or header when tightening set screw.

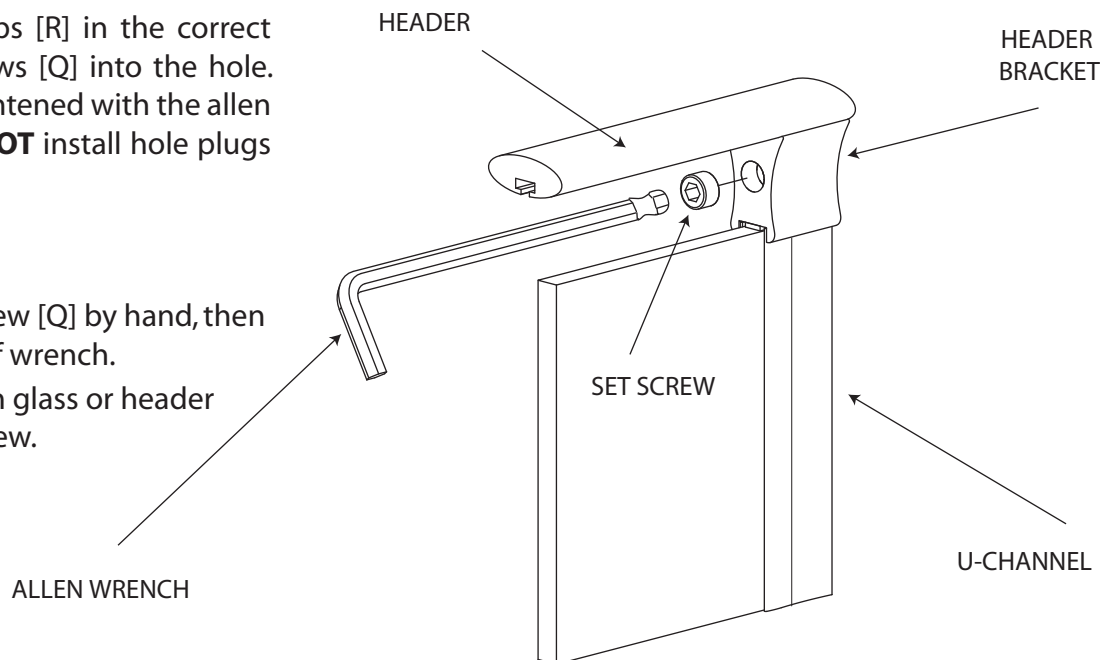

14

 Place handle on door prior to installation.

Note: See 8" Door Pull Assembly Instruction located in the back of this instruction.

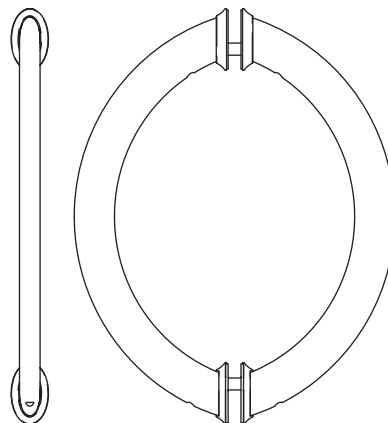

15 Using the alcohol pads [W] wipe the hinge notches on both the panel [G3] and the door [G1]. (Allow parts to dry before continuing). Remove the back plates from both hinges [F]. Place a gasket on the hinge [F] and place fixed part of hinge onto the panel [G3]. Now place another gasket between the glass and attach the back plate. Repeat this on both panel notches and open the hinges outward.

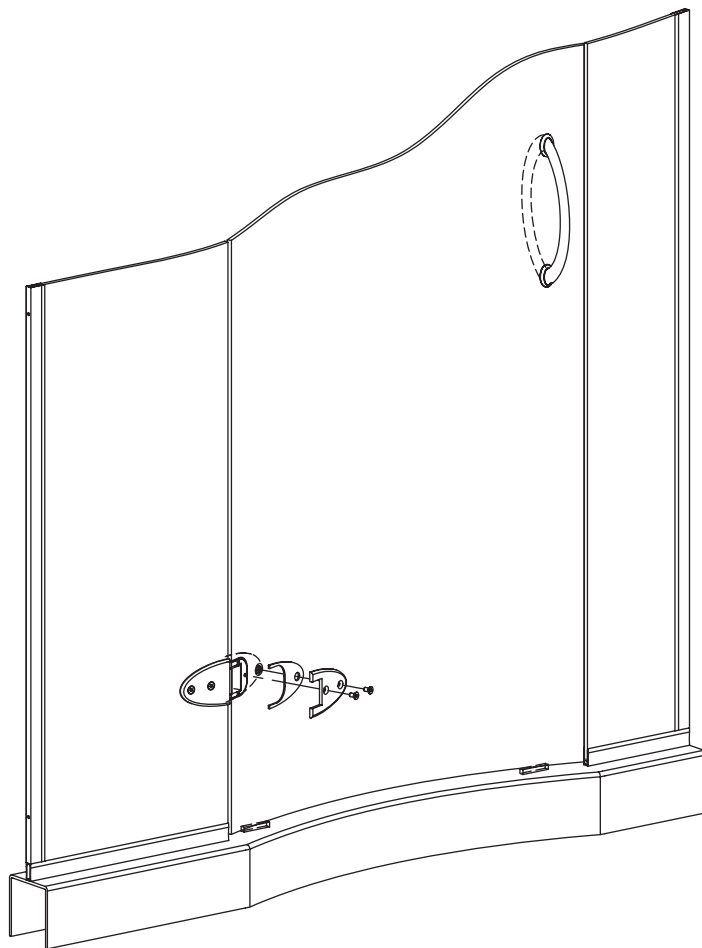
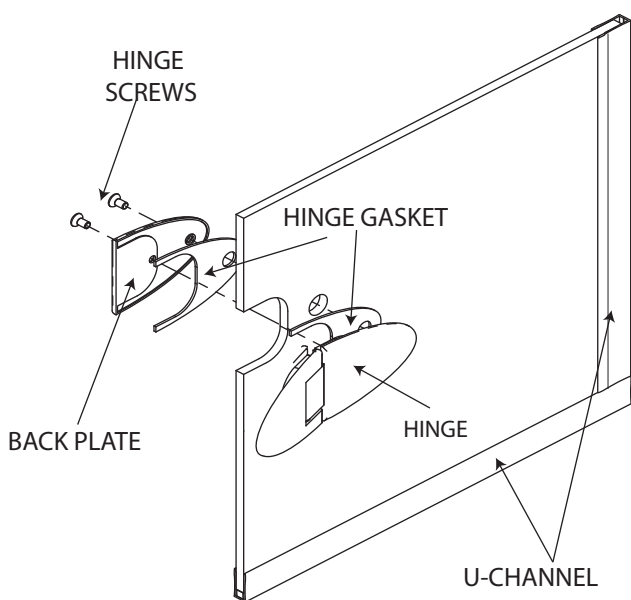

16 The door is best installed with two people. Position one person on each side of door panel and carefully place the door panel over the hinge notches. As the person to the outside of the door holds the door panel, the other person installs the hinge back plates, gaskets, and screws. To complete installation. Now repeat the same process for each hinge.

Note: When fully tightened, the screws should begin to have "creaking" sound.

Carefully and slowly close door and inspect door-panel gaps for interference. **Do not force door closed.**

Note:

If interference exists hinges can be loosened to adjust gaps. The gap should be $3/16''$ on each side of the door and $5/16''$ between the door and threshold at the highest point.

Re-tighten all screws after final adjustment.

If hinge is scratched in tightening process touch up paint may be used.

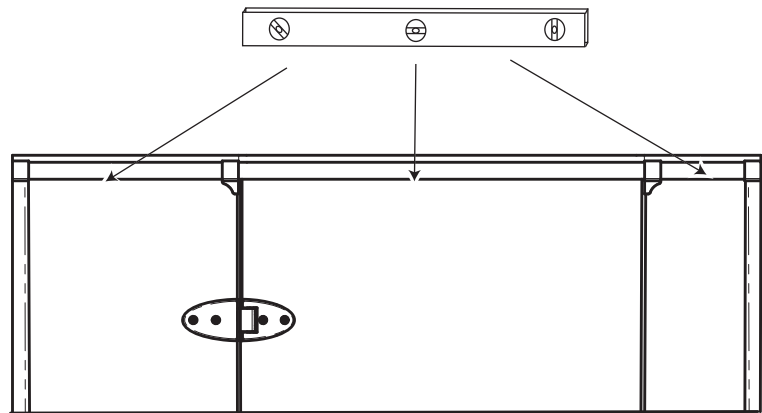
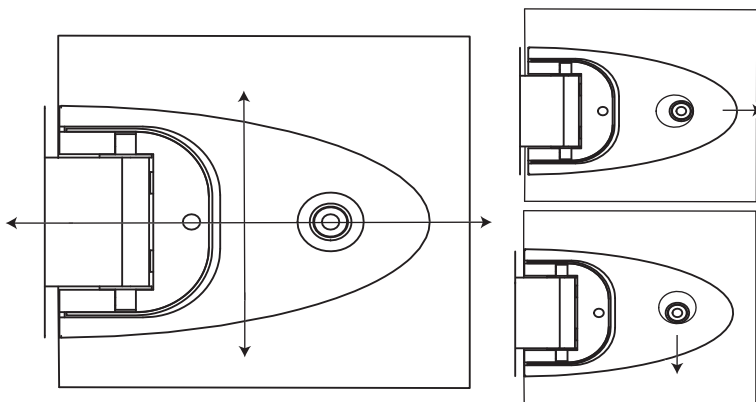
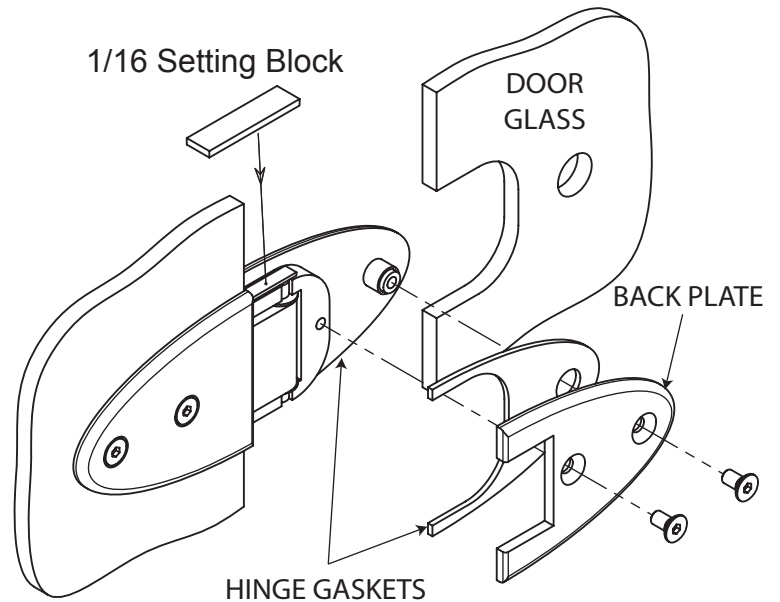

17 Press the hole plugs [P] into the set screws [Q].

DO NOT install these plugs until completely satisfied with glass position.

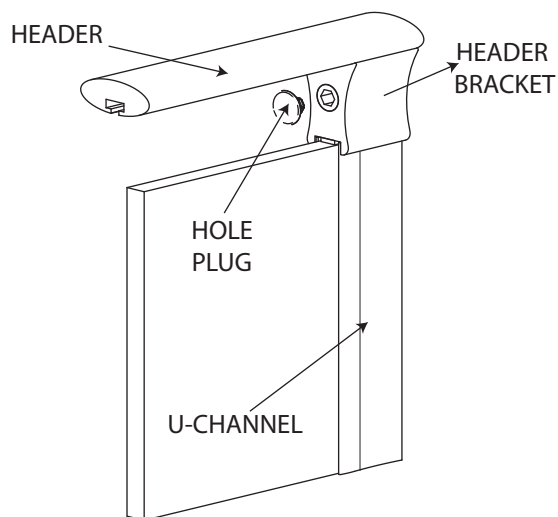

18 Place drip vinyl [D] onto the bottom of the door panel [G1]. The drip vinyl [D] should enclose the bottom gap under the door. It may be pulled up or down, as required, to create a light seal to the threshold.

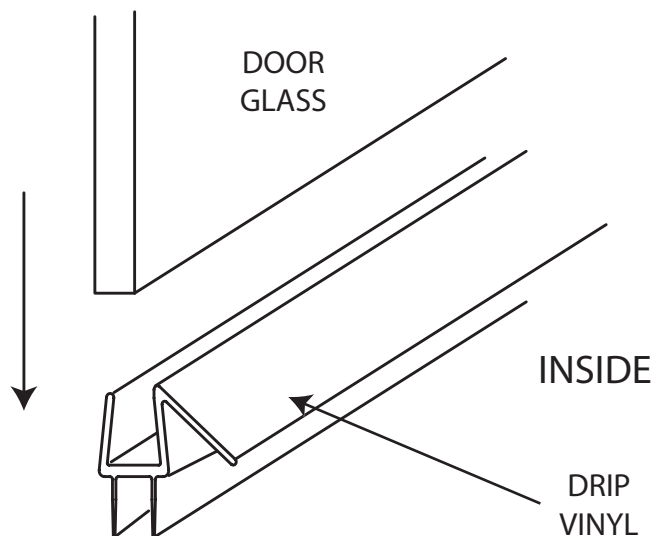

19 On the interior edge place a low tack tape on the glass, about 1/8" to 3/16" above the u-channel [B] both vertically and horizontally. Run a small bead of silicon along this edge. Next on the interior run a bead of silicon between the u-channel [B] and the threshold and also between the u-channel [B] and the wall. After completing remove the tape.

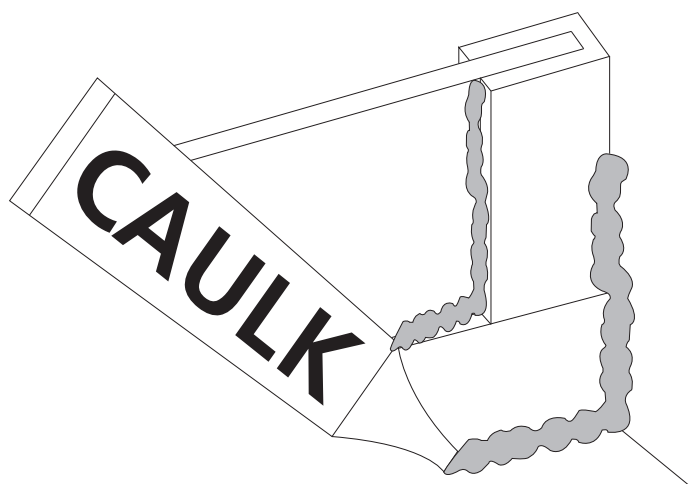

20 Install the unit logo. Remove one side of double sided tape, align and press double sided tape into concave side of logo. Remove opposite side of double sided tape. Use the template to place the Preceria logo [Z] on to the top hinge. Press firmly.

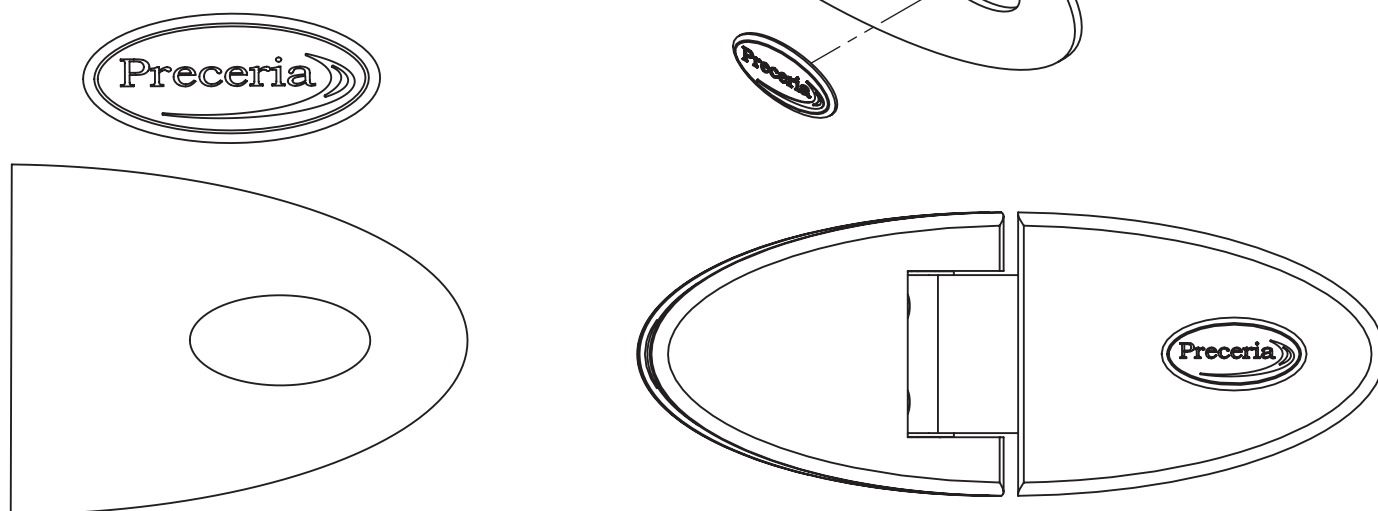

Note: Installation of this logo will allow Basco personnel to identify this product if a warranty issue occurs.

8" Door Pull Assembly Instructions

SC4017

The 8" back to back pull contains 6 component, which are as follows: two handles, four handle plates, four handle gaskets, four set screws, two handle pins and two bushings. These components will come assembled and ready to install.

Step 1: Place one handle plate [I] and one gasket over each handle pin.

Step 2: Slide the handle pins through the glass. The mounting holes for the set screws should face downward. After sliding the handle pins through the glass, place a bushing and another handle plate on each of the handle pins.

Step 3: Place the other handle over the handle pins, with mounting hole facing downward. Push the handles tightly together and tighten the set screws with the allen wrench.

Handle Parts

H	Handle	SC888	2
I	Handle Plate	SC4021	4
J	Handle Gasket	SC4016	4
K	Set Screw		4
L	Handle Pin	SC4215	2
N	Bushing	SC4230	2

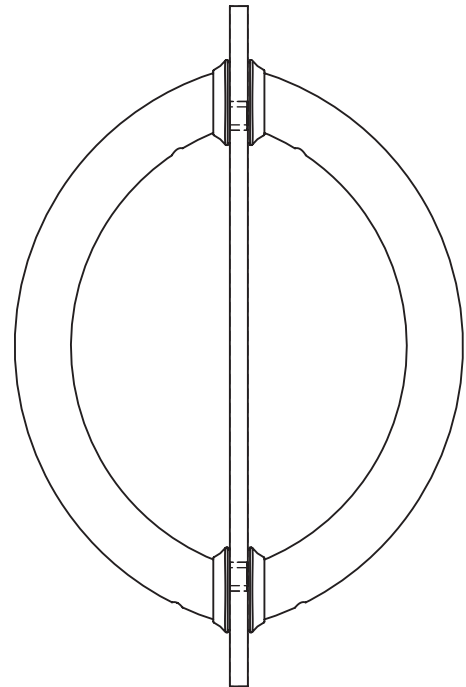
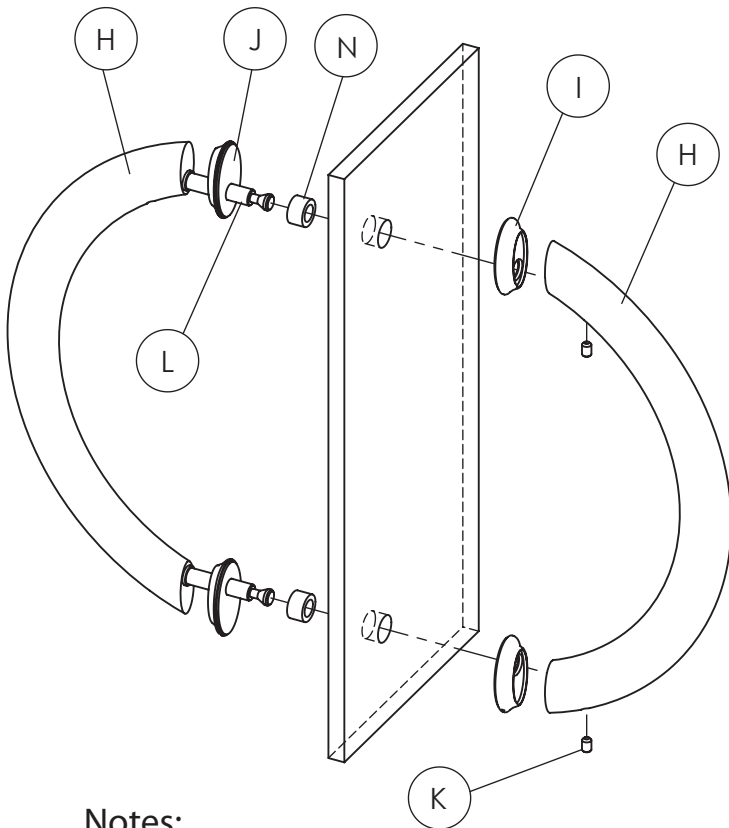

Notes:

Make sure both handles are seated in their corresponding handle plates before tightening set screws.

When assembling and removing door pull, hold handle from at the center and push or pull with equal force on both end.

If removing door pull, loosen all four set screws and gently pull apart from the center of each handle.

Appendix - A Notch Panel

If your unit has been purchased with a notch panel option, two additional pre-cut pieces of u-channel will be provided. These two pieces of u-channel will be mitered and cut to size based on the opening dimensions provided with your order. Please follow the same instructions provided in step (3 thru 6), for mounting threshold and wall u-channels, to mount the notch panel u-channels. Below are illustrations to clarify the mounting orientations.

