

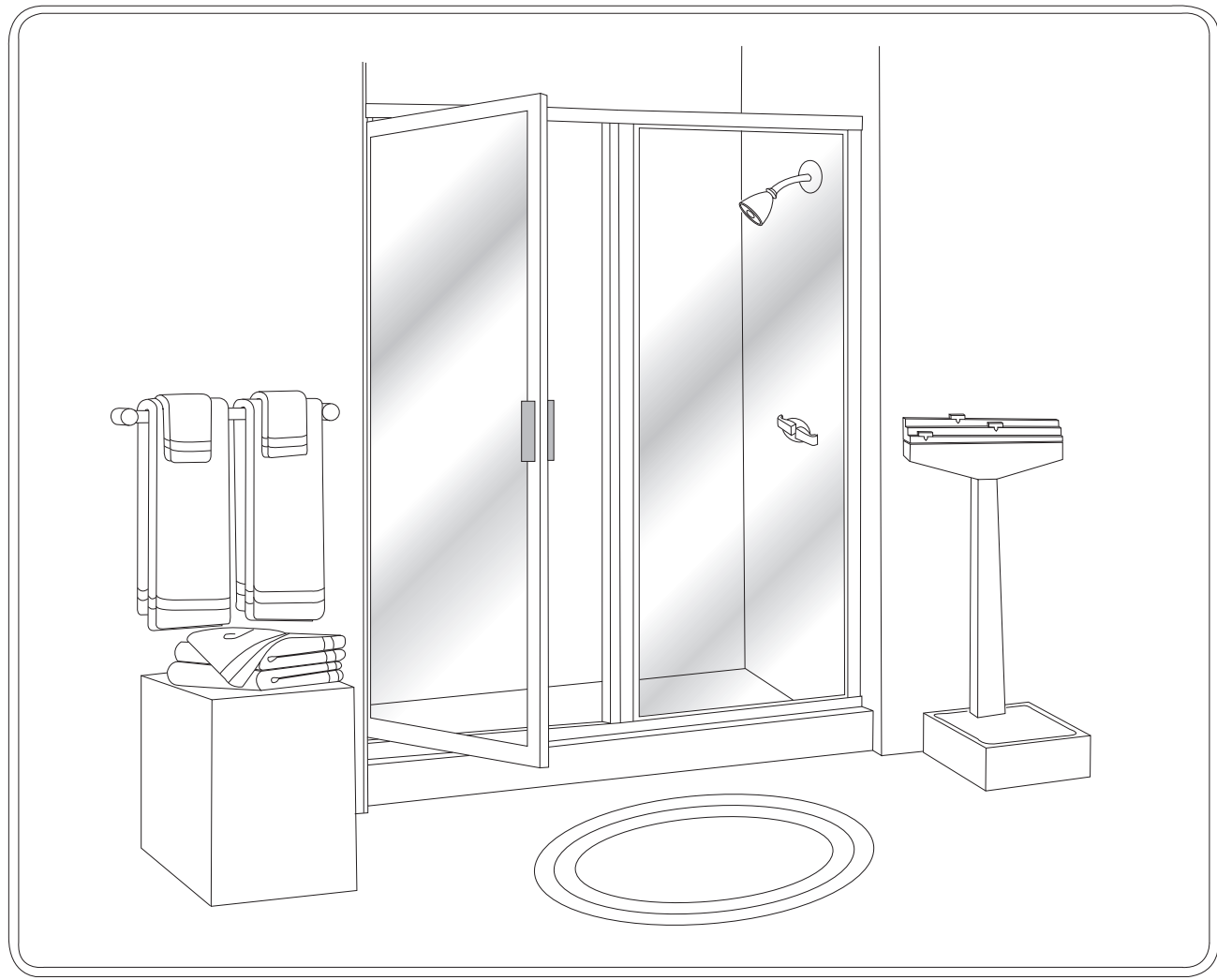

INSTALLATION INSTRUCTIONS

UNIT No. 135/735 THIN-LINE SHOWER ENCLOSURE

**NEED
INSTALLATION
HELP?**
Call
1-800-45-BASCO (452-2726)
Monday - Friday
8:00 A.M. - 4:30 P.M.
Eastern Time



MAINTENANCE: Two primary materials are used to manufacture your new Basco enclosure: tempered glass and anodized aluminum. To assure a long lasting finish on the enclosure, wipe it down with a towel after each use. Never use a scouring agent to clean the aluminum.

For occasional, more concentrated cleaning efforts, we find that *Comet Non-Abrasive Bathroom Cleaner* works extremely well. Be sure that any over spray falling on the aluminum frame is rinsed thoroughly and dried. Many over-the-counter cleaners, if applied to the aluminum and left on, will harm the metal finish and cause permanent damage, even though their directions indicate safe use on shower doors.

INSTALLATION NOTES: Unpack your unit carefully and inspect for freight damage. Lay out and identify all parts using the instruction sheets as a reference. Before discarding the carton, check to see that no small hardware parts have fallen to the bottom of the box. If any parts are damaged or missing, refer to the descriptions noted in the instructions when contacting your dealer for replacements.

Handle the glass panels carefully and protect the edges. Safety tempered glass is very resistant to breakage, but the sharp corners of the panels can damage tile and floor surfaces.

Please wear safety glasses whenever drilling or cutting. When drilling holes in the ceramic tile or marble, use a center punch and hammer to carefully break the surface glaze so the drill can start without skidding.

To install your BASCO Shower Door you will need the following: tape measure, level, #2 Phillips screwdriver, 3/16" wrench, drill, 1/8" and 3/16" drill bits, hacksaw, pencil, and caulking (clear silicone recommended). Optional tools include a miter box for cutting parts to length, files, center punch, and masking tape.

NOTE: Tempered glass cannot be cut.

Although safety tempered glass is very resistant to breakage, the glass can still break if unequal pressure is placed on it during installation. Use caution. In addition, the sharp corners of the panels can damage tile and floor surfaces, so it is best to handle the glass panels carefully and protect the edges.

IDENTIFICATION GROOVE

NOTE : Each magnetic strip has an indentation groove on the exposed surface. For proper alignment, the grooves should be opposite each other (see detail).

Identification Groove

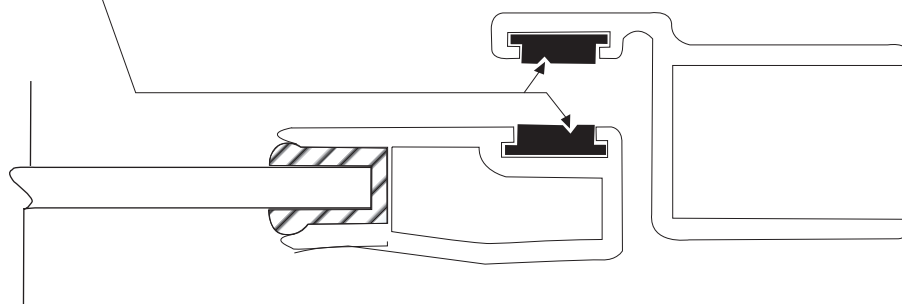

135/735 THIN-LINE PARTS LIST

- | | | |
|------------------------------------|--------------------------------------|---------------------------------------|
| A. 1 Curb | L. 1 Glazed Door Panel | X. 1 Nylon Spacer |
| B. 2 Wall Jambs | M. 1 Pivot Jamb | Y. 2 Nylon Pivot Bushings |
| C. 6 Plastic Wall Anchors | N. 1 Strike Jamb (Magnetic) | AA. 1 Security Washer |
| D. 6 #8 x 1 1/2" Truss Head Screws | P. 2 Snap-in Fillers | BB. 1 Interior Door Handle |
| E. 2 Plastic Setting Blocks | R. 1 Drip Rail | CC. 1 Exterior Door Handle |
| F. 1 Fixed Glass Panel | S. 2 Drip Plugs | DD. 2 #6 x 1 1/4" Round Head Screws |
| G. 1 180° Post | T. 1 Tapered Drip Vinyl | EE. 4 Pcs. Vert. Glazing Vinyl (72") |
| H. 1 Header | V. 1 Roll Double Stick Tape | FF. 2 Pcs. Horiz. Glazing Vinyl (72") |
| J. 12 #8 x 1/4" Truss Head Screws | W. 2 #10 x 7/16" Sq. Head Set Screws | GG. 1 Basco Decal |
| K. 2 Clear Vinyl Jamb Seals | | |

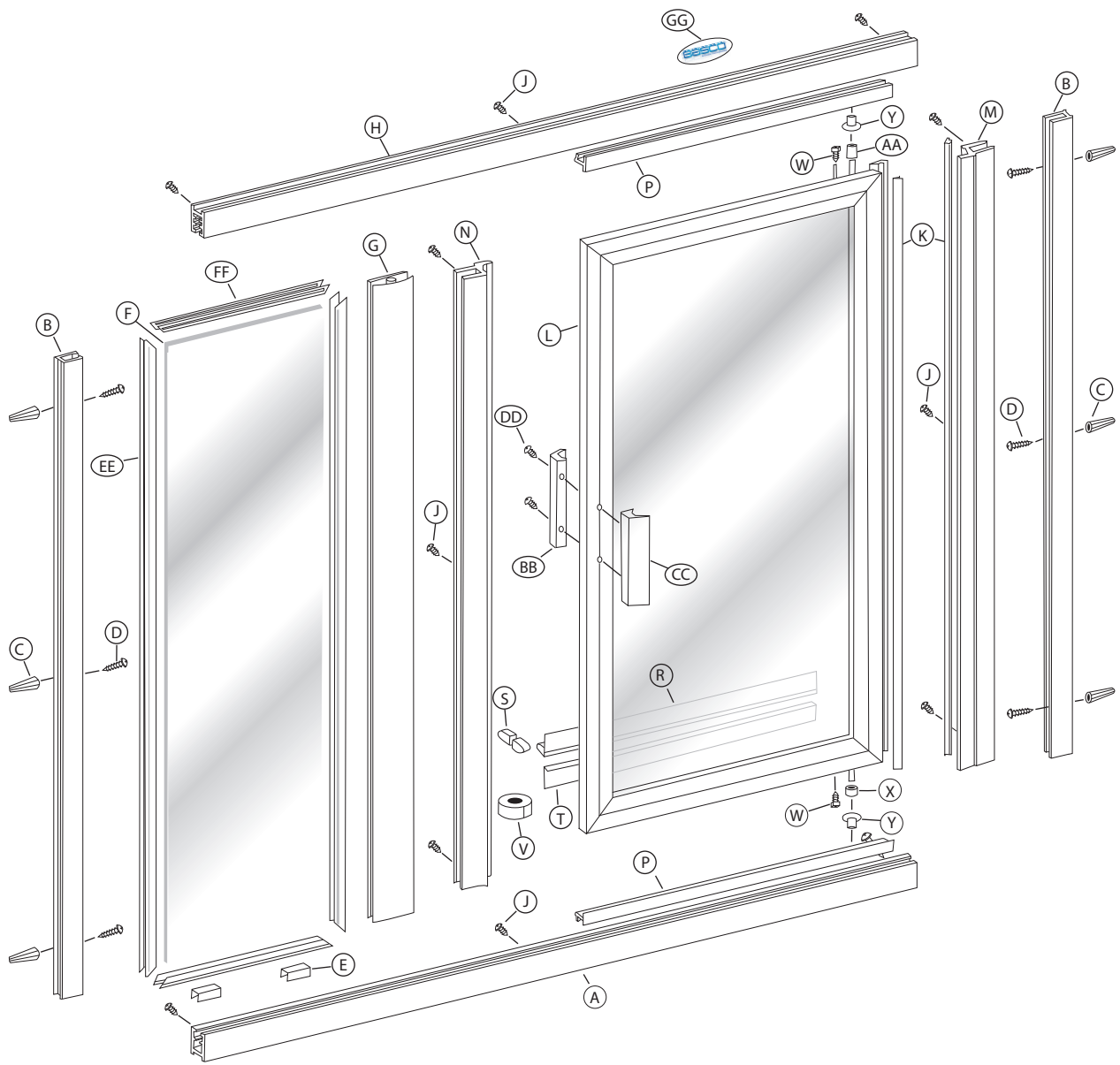

1

The BASCO 135/735 Thin-Line Shower Enclosure is completely reversible and may be installed pivot-left or pivot-right. The door may pivot from the wall or from the center post. For maximum waterproofing, the pivot jamb should be opposite the showerhead. Using the diagram, to determine the correct position for the door in your particular installation. This instruction sheet depicts a pivot-right installation.

CAUTION: For safety reasons, the door panel must always open *outward*.

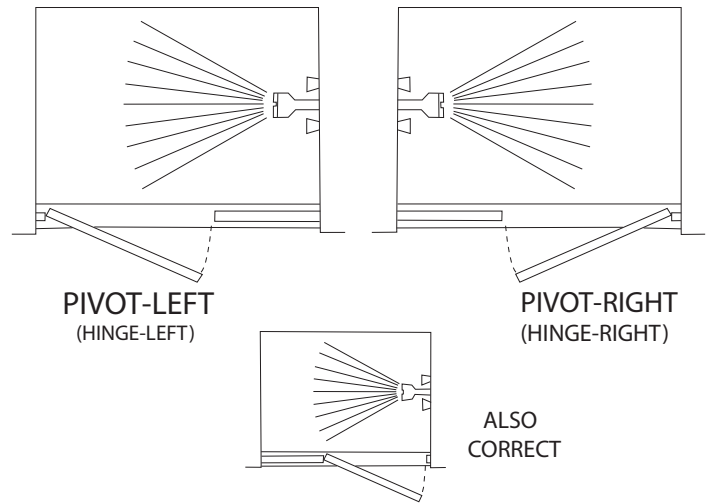

2

Measure the opening at the bottom of the shower stall and cut the curb [A] (with weep slots) to fit the full width of the opening. If required, use a file to round the lower corners of the curb to fit the shower sill properly.

Using a 3/16" drill bit, drill the interior face of the curb on both ends as shown.

Position the curb in the middle of the sill with weep slots to the interior and mark its position with a pencil line along the interior and exterior base.

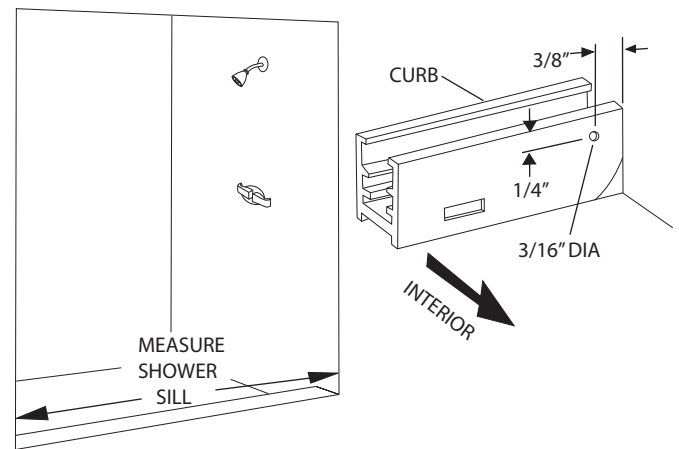

3

Place the two wall jambs [B] into the ends of the curb [A]. Masking tape may be used to hold the curb in place during this operation. Plumb the jambs and mark the hole locations on the wall. Remove all parts and drill the walls for mounting hardware.

For tile or marble walls, drill six 7/32" diameter holes and insert the plastic wall anchors [C]. A center punch helps locate the holes accurately.

Attachments to fiberglass or acrylic units can be made in two ways. If reinforcement is built into the wall of the unit, drill three 1/8" holes to install mounting screws directly into the reinforcement. If walls are not reinforced, drill 7/32" holes and install plastic wall anchors or toggle bolts (toggle bolts not supplied by BASCO).

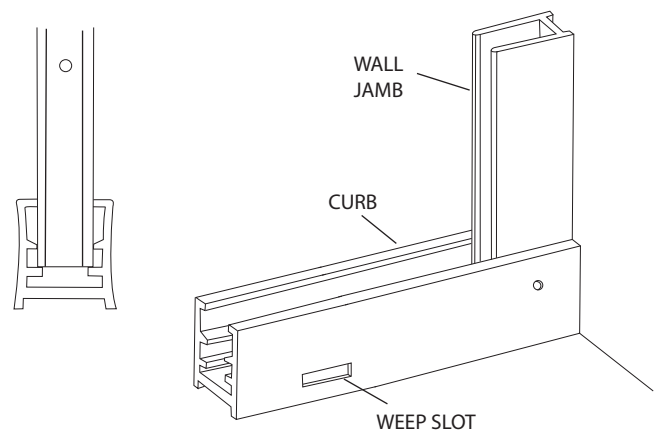

4

Wipe the shower walls and sill, curb [A] and wall jambs [B] with a clean, dry cloth to remove any dust or debris. Apply a 1/4" bead of caulk along the inside of both of the pencil lines marked in Step #2. Carefully replace the curb in the exact position marked. Caulk the inside of the curb where it meets the wall.

Replace both wall jambs and attach to the walls with six #8 x 1 1/2" truss head screws [D].

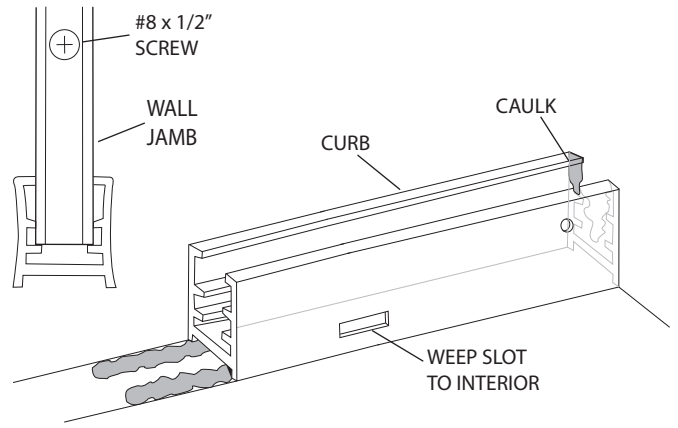

5

Place the setting blocks [E] in the curb [A] as shown to support the fixed glass panel [F]. The setting blocks should be positioned approximately 3" from each corner of the glass panel. Remove any protective strips from the glass panel and set it into place. It should rest on the setting blocks and be engaged approximately 1/2" into the wall jamb [B]. A strip of masking tape 1/2" from each vertical edge of the glass will aid alignment.

Press the 180° post [G] into the curb and position to overlap the glass panel by 1/2". Use masking tape to hold the post in position temporarily.

NOTE: To facilitate out-of-plumb walls, the 1/2" glass bite may be varied from 1/4" to 3/4".

NOTE: IF QUICK-N-STALL OPTION IS ORDERED, THE SETTING BLOCKS ARE NOT NEEDED.

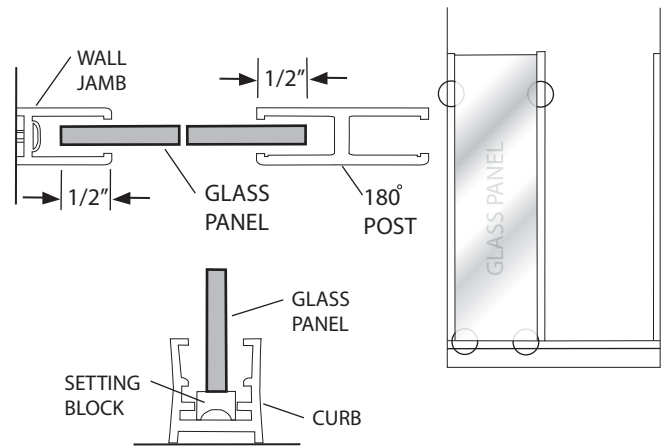

6

Measure the wall-to-wall opening at the top of the wall jambs [B] and cut the header [H] to fit the exact opening. Using a 3/16" drill bit, drill the interior face of the header on both ends as shown.

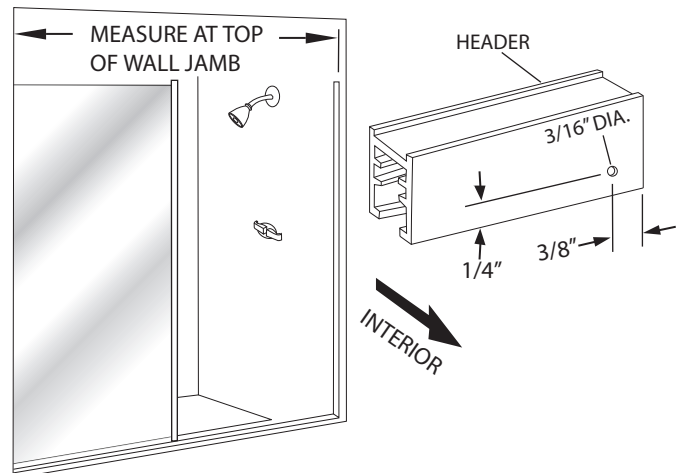

7

Press the header [H] over the wall jambs [B] and the 180° post [G]. Plumb the post, moving it laterally as required to maintain proper coverage on the fixed glass panel [F]. The minimum horizontal dimension for the door opening is the door panel width (see the graphic in Step #8) plus 1/2", maximum is the door panel width plus 1 3/4". Using the holes in the ends of the header and curb as a guide, drill four 1/8" holes into the wall jambs. Drill two 1/8" holes thru the header and curb into the 180° post as shown, then enlarge the two outer holes with a 3/16" drill for clearance on the self-tapping screws. Secure the header and curb to the wall jambs and 180° post with six #8 x 1/4" truss head screws [J].

CAUTION: Slide the glass panel away from the wall jamb before drilling to prevent damage or breakage.

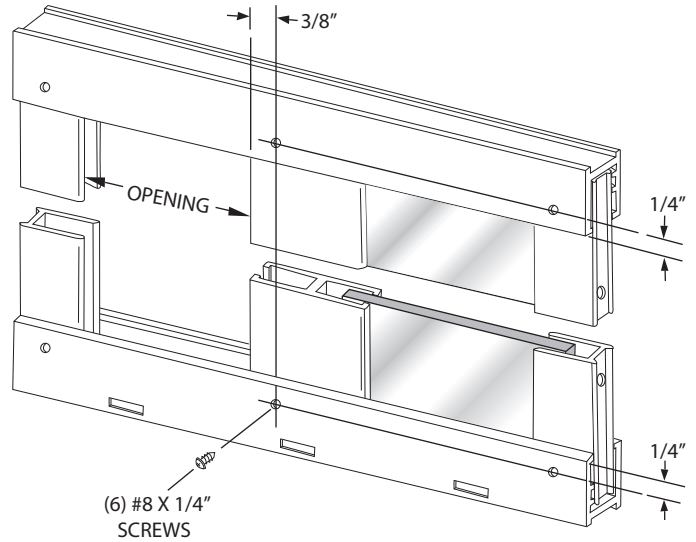

8

Strip two clear vinyl jamb seals [K] into the door panel [L] splash guard and the pivot jamb [M] and trim flush at both ends. Both vinyls should be turned to trap water from the shower head. Secure the vinyls with a small quantity of glue or caulk at each end or by carefully crimping the vinyl pocket. Set the door panel aside.

Press the pivot jamb and strike jamb [N] (with magnetic strip) over the wall jamb [B] and 180° post [G]. Refer to Step #1 for the proper handling of the door.

NOTE: The magnetic strip on the strike jamb must face the exterior and the clear vinyl jamb seal on the pivot jamb must face inward.

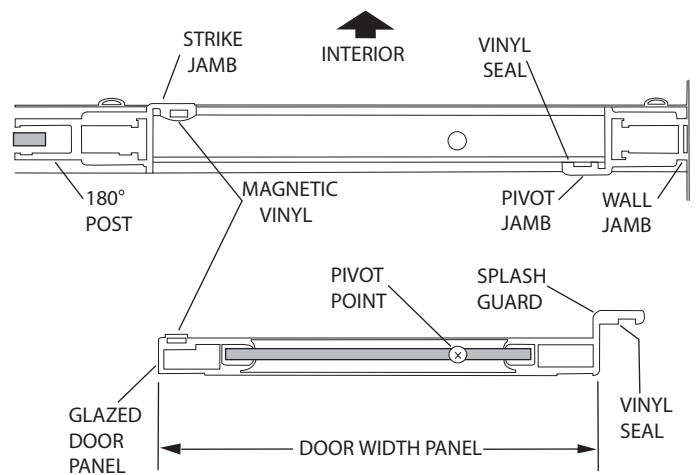

9

Snap the fillers [P] into the curb [A] and header [H] between the door jambs with the **RAISED LIP TO THE EXTERIOR** and the pivot holes toward the pivot jamb. Center the curb filler in the curb between the pivot and strike jamb (use masking tape to hold in position).

NOTE: The snap-in-filler should be exactly 3/8" longer than the door panel width.

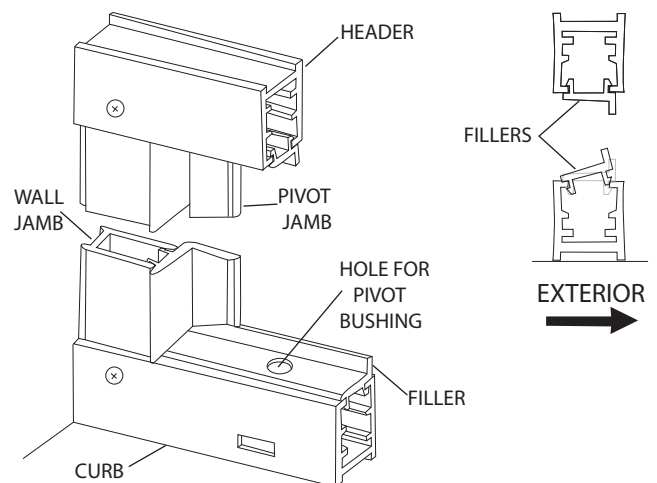

10

Pull the bottom of the pivot jamb [M] tight to the curb filler [P] and plumb the jamb. Drill two 1/8" holes thru the pivot jamb and into the wall jamb [B] 3/8" to 3/4" from the wall and approximately 1/4" vertically from the ends of the jamb. Drill a third hole centered between the first two and enlarge the outer holes with a 3/16" drill for clearance on the self-tapping screws. Attach the pivot jamb permanently with three #8 x 1/4" truss head screws [J].

Slide the header filler [P] tight against the pivot jamb. Push the strike jamb [N] tight against the fillers top and bottom. With the pivot jamb plumb and both fillers tight between the two door jambs, the strike jamb also will be plumb and parallel to the pivot jamb. Attach the strike jamb to the 180° post [G] in the same manner as the pivot jamb.

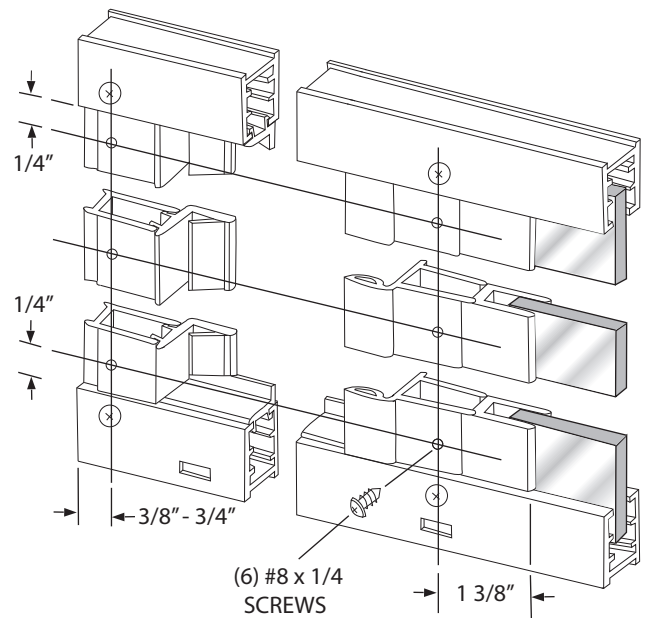

11

Insert the two #10-24 x 7/16" square head set screws [W] into the threaded holes in the pivot blocks in the top and bottom rails of the glazed door panel [L]. Position the pivot pins 1 1/2" from the pivot side of the door (the side opposite the magnetic strip). Tighten the set screws just enough to prevent the pivot blocks from moving (finger tight plus a quarter turn). A 3/16" wrench will fit the set screw heads.

Press the white nylon spacer [X] over the bottom pivot pin on the door panel.

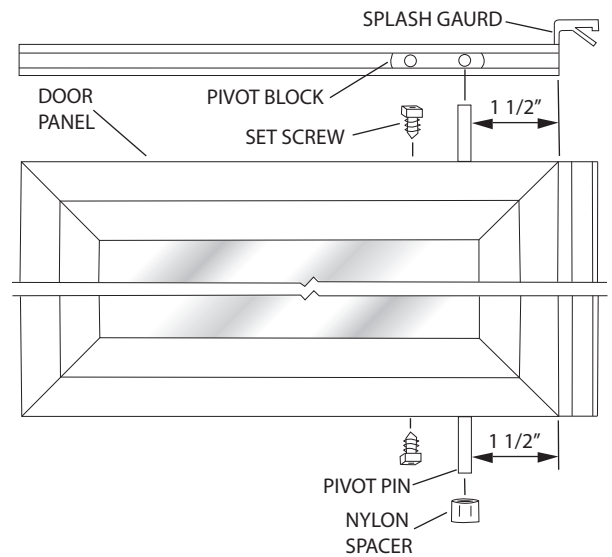

12

Insert the two nylon pivot bushings [Y] into the pivot holes in the head and curb fillers [P].

Lift the door panel [L] and insert the top pivot pin into the pivot bushing in the header filler. Hold the door vertical and insert the bottom pivot pin into the pivot bushing in the curb filler. It may be necessary to remove the header retaining the screws and raise the header slightly to install the door.

When the door has been set into place, snap the security washer [AA] over the top pivot pin to hold the upper pivot bushing in place and prevent accidental dislodging of the door.

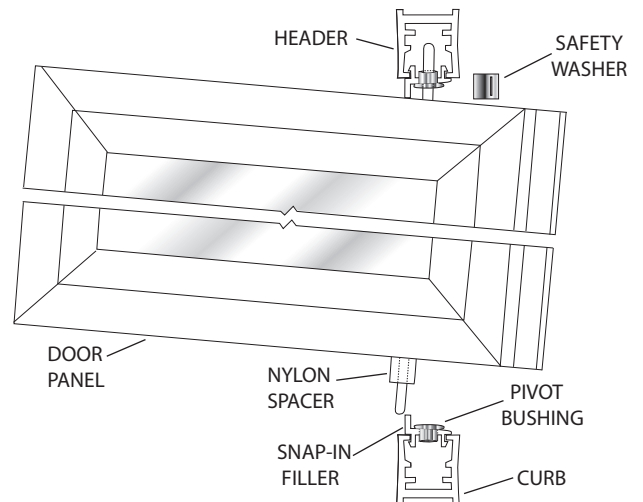

13

Clean the bottom door rail and the drip rail thoroughly with rubbing alcohol to ensure proper adhesion. Unroll the double stick tape [V] and carefully apply it to the back of the drip rail (do not peel the tape backing yet).

Insert the tapered drip vinyl [T] into the drip rail. Position the drip rail flush with the bottom and pivot side of the door panel [L], then raise the strike side until the bottom edge of the drip vinyl is parallel to the curb [A]. Mark the location of each end of the drip rail.

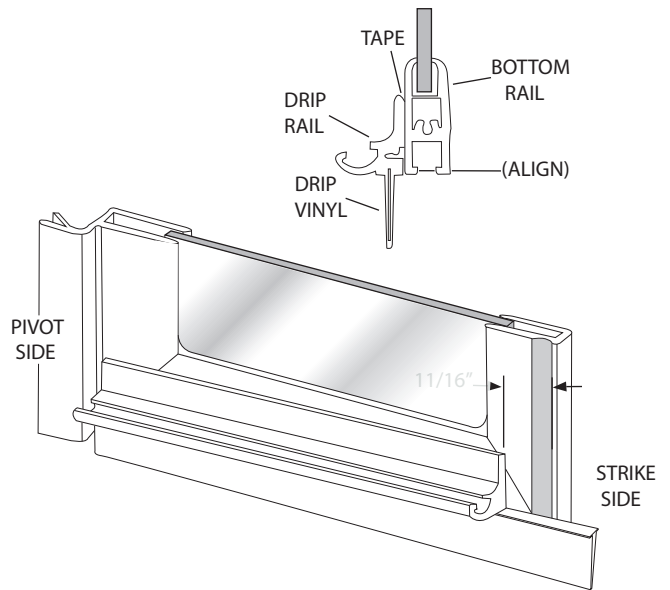

14

Adjust the drip vinyl [T] by sliding it left or right until it almost touches the curb. Trim the vinyl (flush with the pivot end and notch 1/4" longer than the drip rail as shown on the strike end).

The drip plug [S] is supplied with a left and right hand plug together. Break the right and left drip plug apart and insert the appropriate plug into the high (strike) side of the drip rail. Discard the unused drip plug. Peel off the tape backing and carefully press the drip rail [R] to the door in the marked position.

NOTE: Cleaners with alcohol content can dissolve the adhesive that attaches the drip rail. To prevent this possibility, place a small bead of clear sealant at the top of the drip rail where it is attached to the bottom rail.

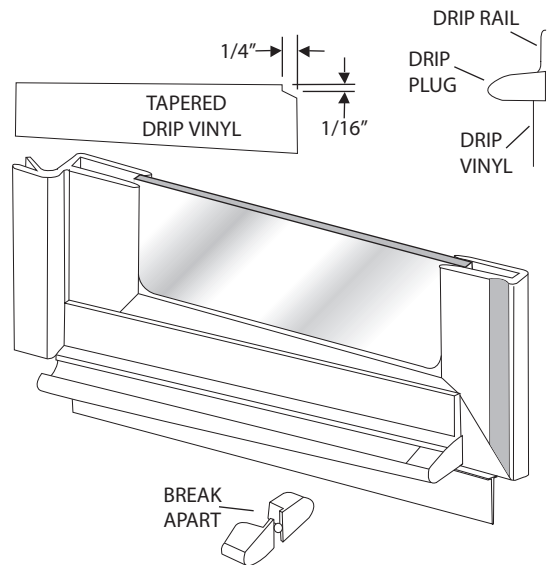

15



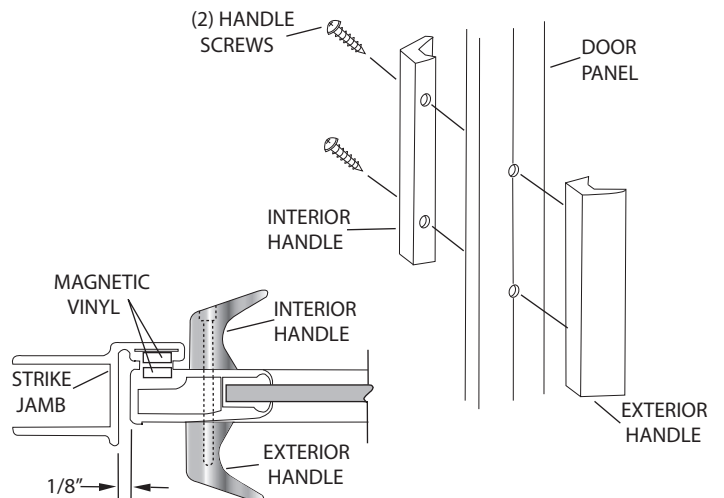

Attach the interior door handle [BB] and the exterior door handle [CC] to the door panel [L] with two #6-32 x 1 1/4" round head screws [DD].

Close the door and check the clearance with the strike jamb [N]. If necessary, loosen the set screws [W] on the top and bottom slide bars and adjust the door panel to align the strike magnets. When the door panel is properly aligned, tighten the set screws securely.

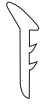

16

Inspect the pieces of black glazing vinyl, and note the two different profiles. The smaller shape [EE] is installed vertically and the larger shape [FF] is installed horizontally. For structural strength and maximum water resistance, these vinyls are designed to fit tightly between the glass and framing. To speed installation, use glass cleaner for lubrication and a small block of wood to press the vinyl into place.

FIXED GLASS PANEL	VERTICAL	HORIZONTAL
1/4" GLASS REQUIRES :	V-219 	V-220 
3/16" GLASS REQUIRES :	V-226 NOTCH 	V-225 NOTCH 

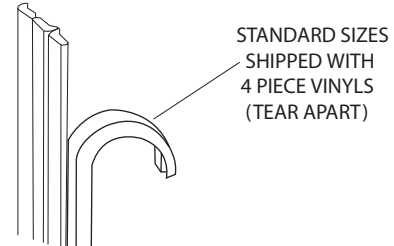

17

Cut four pieces of the smaller vinyl [EE] 1" longer than the vertical opening (to prevent gapping from shrinkage) and trim the ends on a 45° angle. Using the masking tape guides, center the first glass panel [F] in the frame. Cut four short (1" – 2") pieces of the small vinyl and press into the jamb and post on each side to hold the glass temporarily.

Take one of the long pieces of vinyl, and starting on the outside exterior jamb, press each end into the frame and work toward the middle. Be careful not to stretch the vinyl. Install the other three pieces in a similar fashion.

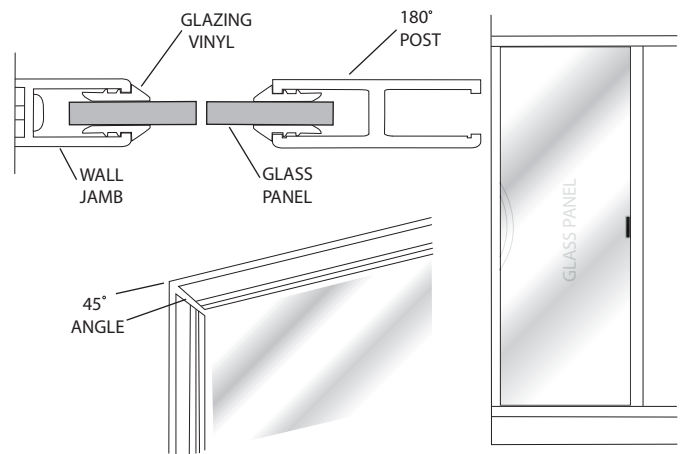

18

Cut four pieces of the larger vinyl [FF] 1/2" longer than the horizontal opening and trim the ends on a 45° angle. Install the top exterior vinyl starting at both ends and working toward the middle. Be careful not to stretch the vinyl.

Install the top interior vinyl and the two bottom vinyls in the same way.

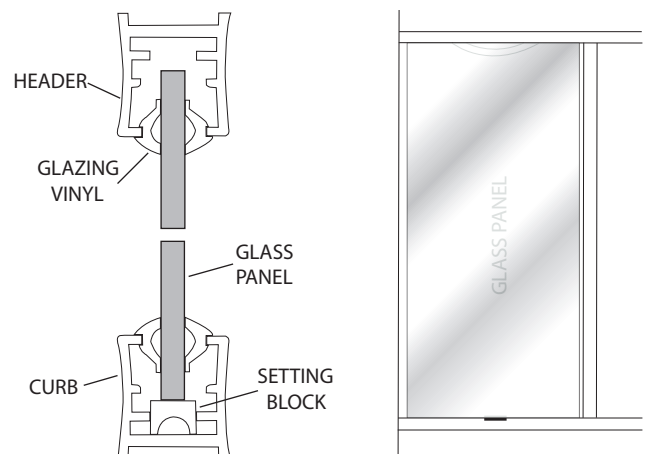

19

Carefully caulk the interior jamb-to-wall and curb-to-base joints. For appearance, you may wish to caulk the exterior joints as well. We recommend you wait twenty-four hours before the first shower to allow the caulking to cure properly.

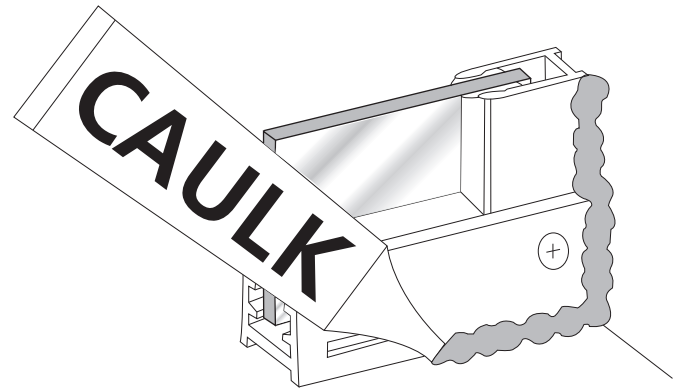

Note: Do not caulk over weep holes

20

Peel off the backing on the BASCO decal [GG] and apply to the inside surface of the header.

