

### UNIT No. 1415NP / 1715NP / 1815NP INFINITY FRAMELESS CONTINUOUS HINGE SHOWER ENCLOSURE WITH NO INLINE POST



**INSTALLATION NOTES:** Unpack your unit carefully and inspect for freight damage. Lay out and identify all parts using the instruction sheet as a reference. Before discarding the carton, check to see that no small hardware parts have fallen to the bottom of the box. If any parts are damaged or missing, refer to the descriptions noted in the instructions when contacting your dealer for replacements.

Handle the glass panel(s) carefully and protect the edges.

Please wear safety glasses whenever drilling or cutting. When drilling holes in ceramic tile or marble, use a center punch and hammer to carefully break the surface glaze so the drill bit can start without skidding.

To install your BASCO Shower Enclosure you will need the following: tape measure, level(s), #2 Phillips-head screwdriver, drill, 1/8" & 3/16" High Speed Steel drill bits, hacksaw, pencil, sharp knife or razor blade and caulking (clear, mildew resistant silicone recommended). Optional tools include a miter box for cutting metal parts, file, center punch and masking tape. An additional 3/16" Masonry drill bit is recommended for tiled applications.

The enclosure is best installed with two people.

## **NOTE: Tempered glass cannot be cut.**

**Although safety tempered glass is very resistant to breakage, the glass can still break if unequal pressure is placed on it during installation. Use caution! In addition, the sharp corners of the glass panels can damage tile and floor surfaces, so its best to handle the glass panels carefully and protect the edges.**

**MAINTENANCE:** Two primary materials are used to manufacture your new BASCO Shower Enclosure: tempered glass and anodized aluminum. To assure a long lasting finish on the enclosure, wipe it down with a towel after each use. Never use a scouring pad/agent to clean the aluminum.

For occasional, more concentrated cleaning efforts, we recommend using *LYSOL*<sup>TM</sup> Non-Abrasive Bathroom Cleaner works extremely well. Be sure that any over spray falling on the aluminum frame is rinsed thoroughly and dried. Many over-the-counter cleaners, if applied to aluminum and left on, will harm the finish and cause permanent damage, even though their directions indicate safe use on shower doors. For more care and cleaning information, please visit our web site;

[www.BASCOSHOWERDOOR.com](http://www.BASCOSHOWERDOOR.com)

For glass treated with AquaGlide<sup>XP</sup>, read the following instructions:

After each use of your shower, use a small plastic bowl, pitcher or a hand held shower head to spray the shower doors with clean cold water. Pour or spray the cold water along the top edge of the glass. The majority of the shower's soapy residual water will drain off. Use a small hand towel to pat dry the remaining droplets or use a squeegee to clear the droplets.

Once a month, use a nylon sponge to go over the wet glass, rubbing in a circular motion. You should feel "sticky" places going back to slick again. Then pour water along the top edge of the glass, as you do after each shower use.

# 1415NP / 1715NP / 1815NP Parts List

- A. Curb Section(w/ weep holes) (1)
- B. #8 x 1/4" Truss Head Screw (9)
- C. Header Section(2)
- D. Wall Jamb (2)
- E. Plastic Wall Anchor (6)
- F. #8 x 1 1/2" Truss Head Screw (6)
- G. Setting Block (4)
- H. Return Glass Panel (1)
- I. Corner Post (1)
- J. Inline Glass Panel (1)
- K. Vertical Glazing Vinyl (2 or 6)
- L. Horizontal Glazing Vinyl (8)
- M. Door Panel Assembly (1)
  - M1. Hinge Jamb
  - M2. Hinge Rail
- N. Curb Snap-in Filler (1)
- O. Header Snap-in Filler (1)
- P. Magnet (1)
- Q. Vinyl (1)
- R. Polycarbonate Strike Jamb (1)
- S. Latch Vinyl (1)
- T. Latch (1)
- U. Handle or Handle/Towel bar assembly (1)
- V. Clear Vinyl Sweep (1)
- W. Basco Decal (1)

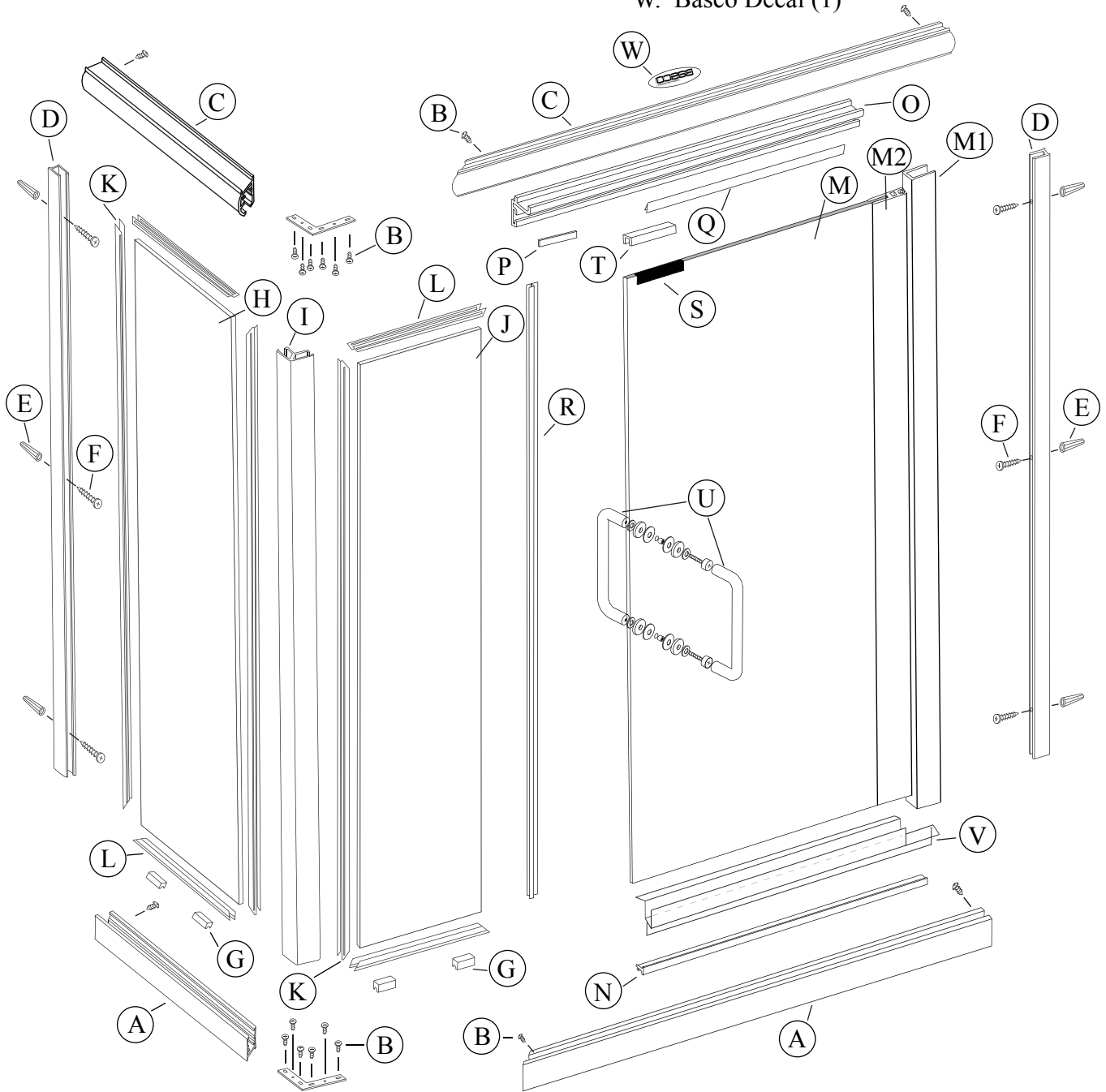

**1** The Basco 1415NP / 1715NP / 1815NP Continuous Hinge Shower door panel is completely reversible and may be installed hinge right or hinge left, depending on the shower head location. Using the illustration, determine the proper hinge side for the door. Careful as to not follow the illustrations exactly.

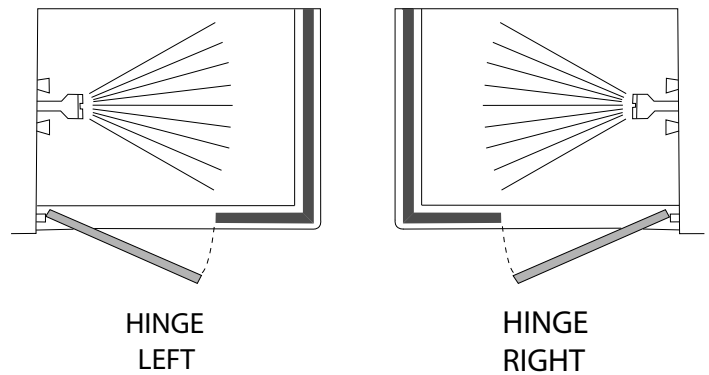

**CAUTION:** For safety reasons, the door must *always open outward*.

**TIP:** Temporarily cover the drain on the inside of the shower with some tape or a large piece of cardboard to prevent small screws, drill bits, etc. from disappearing.

**\*\* Skip step #2 if header and curb sections are pre-assembled \*\***

**2** Assemble the two curb sections (w/ weep holes) [A] by sliding an anchor plate into the mitered ends and forcing the sections together. The weep slots in the curb must be to the inside. Using the *slotted* holes in the anchor plate as a guide, drill matching 1/8" holes into the curbs. Be sure the mitered ends are tight against each other. Secure the anchor plate to the curb sections with four #8 x 1/4" truss head screws [B]. Be sure there is no gap in the mitered joint when tightening. Drill and install two screws through the round holes in the bracket as well .

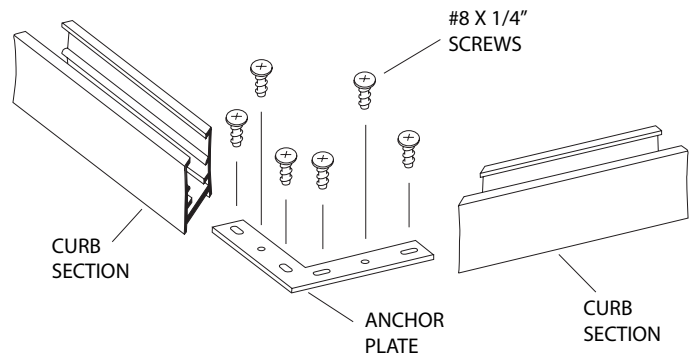

Assemble the two header sections [C] in the same manner.

**3** Place the curb assembly on the shower sill. The assembled curb will sit near or on the center line of the shower sill. If required, use a file to round the ends of the curb assembly to tightly fit the shower opening.

Using a 3/16" high speed steel drill bit, drill the interior face of the curb *at both ends* as shown. These holes may be pre-drilled from the factory.

Place the curb assembly back on the shower sill and mark its location with a pencil along the interior and exterior the full length of both curb sections.

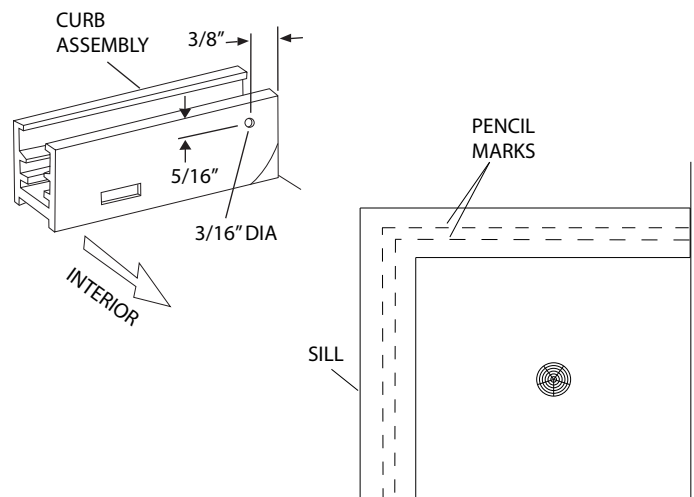

**4** Place one wall jamb [D] into the curb against the wall. Using a level, plumb the wall jamb and mark the hole locations on the wall with a pencil. Repeat this step for the other wall jamb. Remove all parts and drill the holes. **TIP:** Tape can be used to temporarily hold the curb in place.

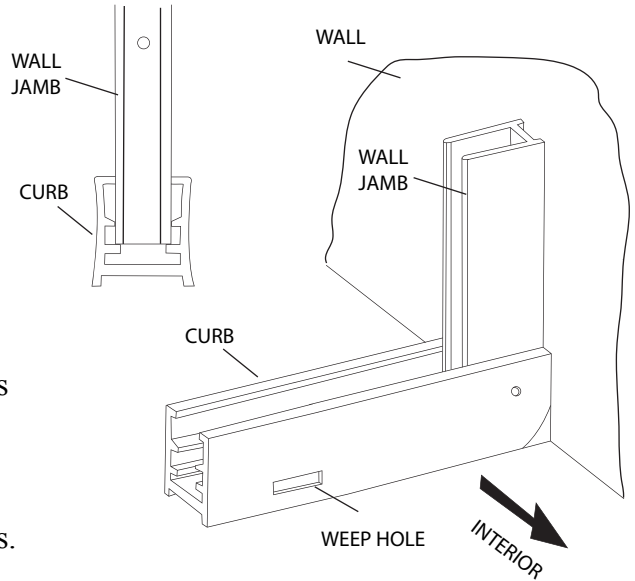

Tile or marble walls:

Drill 3/16" diameter holes into the walls and insert the plastic wall anchors [E].

Fiberglass or acrylic units can be done two different ways.

If the walls are not reinforced, drill 3/16" diameter holes and insert the plastic wall anchors. (Toggle bolts may be used instead but they are not provided).

If the walls are reinforced, only drill 1/8" diameter holes.

**5** Wipe the shower walls, sill, curb & wall jambs with a clean, dry cloth to remove any dust or debris. Apply a 1/4" bead of silicone along the inside of the pencil lines that were marked in Step #2. Carefully place the curb on the sill, over top the silicone, in the position marked.

Silicone the inside of the curb at both ends where it meets the wall, over the anchor plate and screws as well as the inside of the mitered joint.

**TIP:** Angle the tip of the silicone tube so that silicone fills under the two "legs" in the curb that the wall jambs sit on and anchor plate slides into. Smooth out with your finger to remove possible air pockets and force the silicone into the cracks and crevasses.

Replace both wall jambs and attach them to the walls with the six #8 x 1 1/2" truss head screws [F].

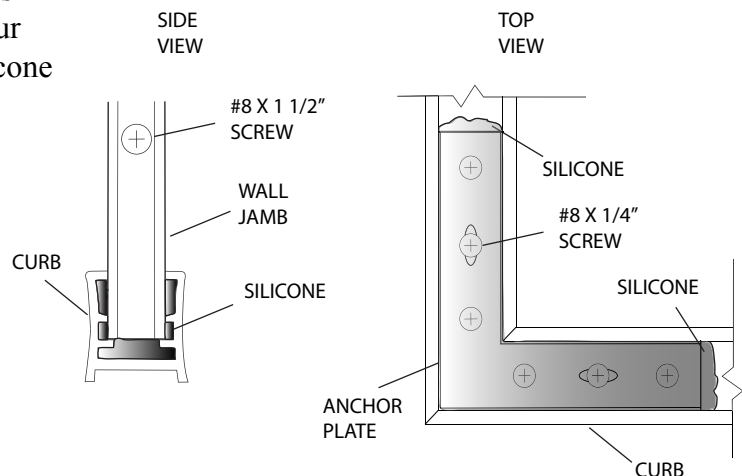
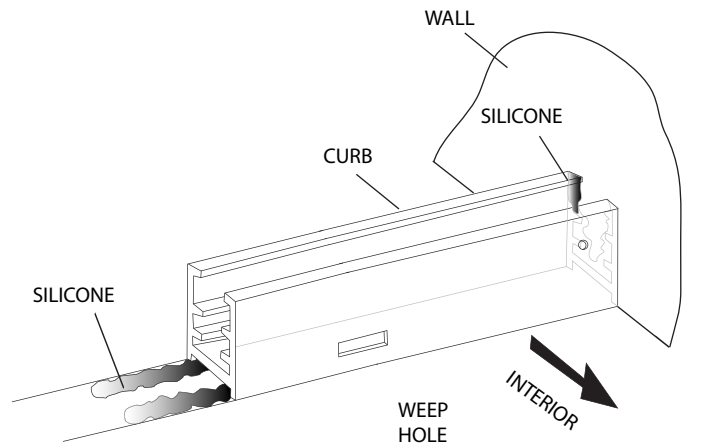

**6** Place four setting blocks [G] into the curb, flat side up, to support the stationary glass panels. Position the blocks so they are centered about 3" from each corner of the glass panel. Set the return glass panel [H] in the curb on the setting blocks and slide into the wall jamb approximately 1/2".

**NOTE:** Patterned glass panels should be installed with the rough or patterned surface on the exterior of the enclosure.

Press the corner post [I], if applicable, into the curb assembly, overlapping the return glass panel by 1/2". Use masking tape to hold its position temporarily.

Place a piece of tape at the top and bottom of the inline stationary glass panel [J] 1/4" from the edge on the side that will go into the corner post. This will aid in setting the door later. Then set the inline glass panel into place.

**\*\*For glass to glass corner option there will be no corner post and the vertical edges of both panels will be polished. Skip the post installation step and install the inline panel overlapping the return panel (see illustration). Stretch tape over the corner where the glass panels meet to secure temporarily.**

**NOTE:** Depending on any out of plumb or level conditions, the panel/metal overlap might vary from 1/4" to 3/4". Use a level to determine if this is necessary.

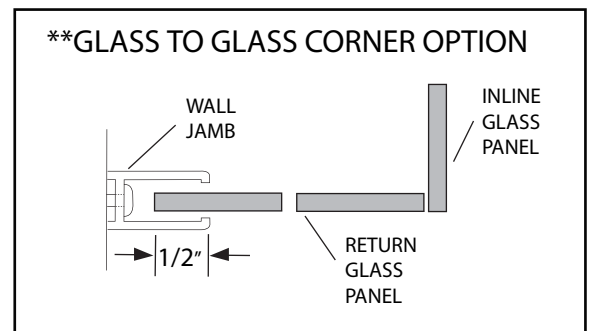
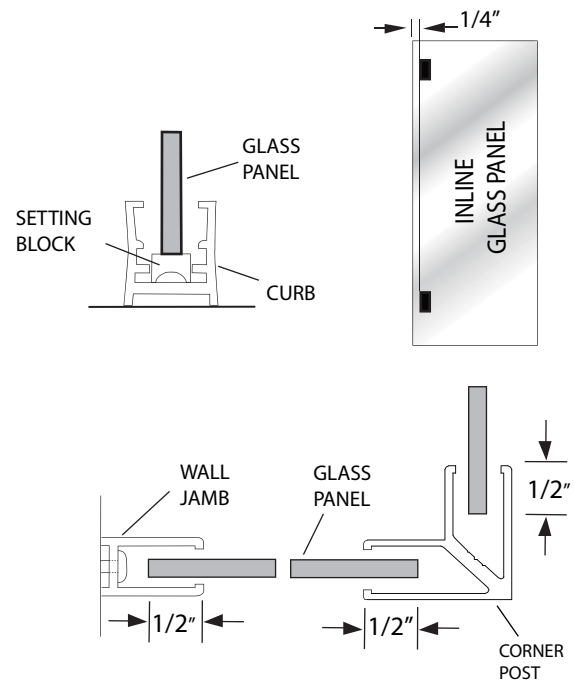

**7** Using a 3/16" high speed drill bit, drill the interior face of the header on both ends as shown. These holes may be pre-drilled from the factory.

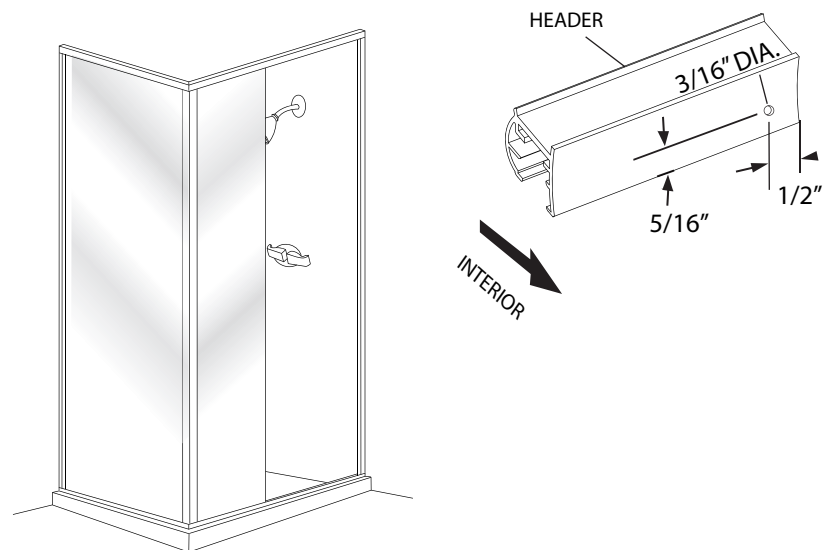

**8** Press the header assembly over the wall jambs and corner post (if applicable). Check both sides of the post for plumb. Adjust as required by varying the overlap of the header over the wall jambs.

Using the 3/16" holes in the ends of the header and curb as a guide, drill four 1/8" holes into the wall jambs. If applicable, also drill two holes thru the header and curb and into the corner post as shown. Enlarge the holes in the header and curb only, not the post, to 3/16" to allow for clearance of the screws.



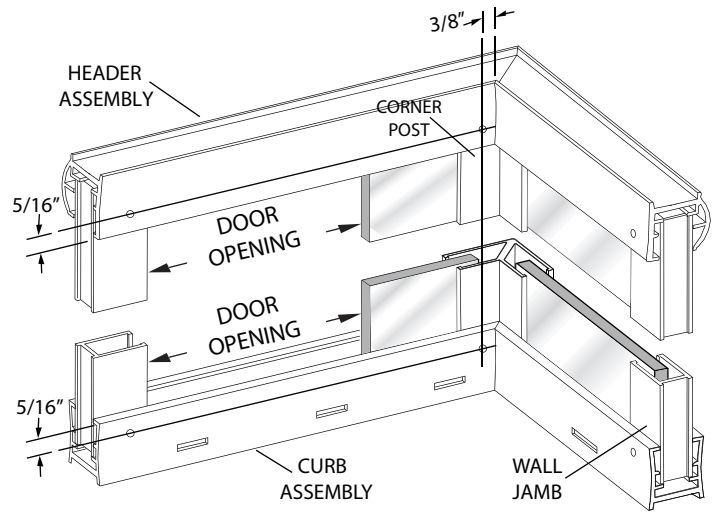

Secure the header and curb to the wall jambs and the corner post using eight #8 x 1/4" truss head screws [B].

**CAUTION:** Slide the glass panel away from the wall and post when drilling to prevent the glass panel from breaking.

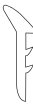

**9** Inspect the strips of black glazing vinyl and note the two different profiles. The flat shaped vinyl [K] is installed vertically and the crescent shaped vinyl [L] is installed horizontally. There should be a minimum of two (2) individual vertical and two (2) individual horizontal pieces of vinyl about a 1/2" wide each. (May need to peel apart from a wider strip). These vinyls are designed to fit tightly between the glass and metal frame. **TIP:** Wet the glass and vinyl with water or glass cleaner immediately before installing vinyl and use a small block of wood to press the vinyl into place.

**NOTE:** Different glass sizes require different vinyl. Refer to the chart for clarification if installation is extremely difficult.

FIXED GLASS PANEL	VERTICAL	HORIZONTAL
1/4" GLASS REQUIRES :	V-219 	V-220 
3/16" GLASS REQUIRES :	V-226  GROOVE	V-225  GROOVE

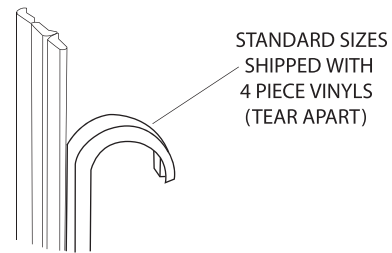

**10** Once the panels are set in place, cut four small pieces of the horizontal [L] (crescent shaped) vinyl about 3" and install them into the header and curb (open side of the crescent shape against the glass). This will help hold the panel in place while installing the door panel.

\*\* Glass to glass corner option: Repeat the above step for the return panel as well

Set the rest of the vinyl to the side for later installation.

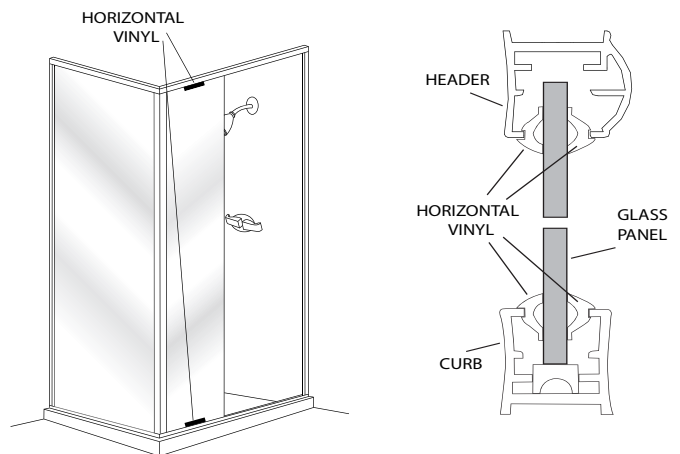

**11** Orient the door [M] to the opening. Grab the door from the inside. The open side of the hinge jamb [M1] should be away from you (see illustration). Carefully lift the door into the opening and slide the hinge jamb completely over the available wall jamb.

Holding the door in the open position, press the curb snap-in filler [N] into the curb, **WITH THE RAISED LIP ON THE EXTERIOR**. Slide the snap-in filler against the stationary panel. Press the header snap-in filler\*\* [O] into the header **WITH THE FLANGE ON THE INTERIOR**. (see illustration)

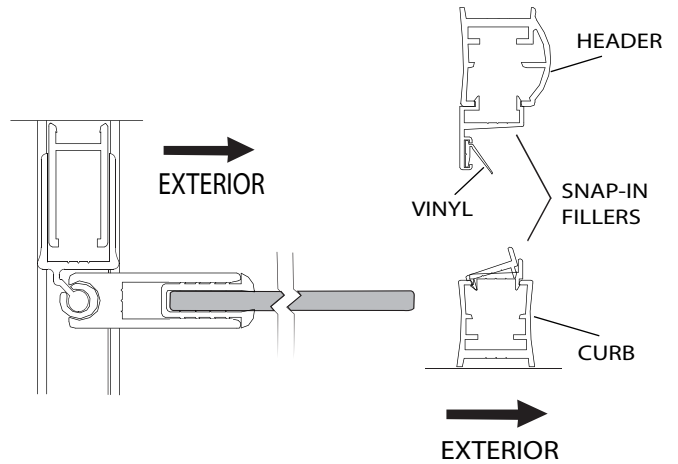

**\*\* Prior to installation, be sure that the magnet [P] and vinyl [Q] are inserted into the flange. The open part of the vinyl should be facing down and the magnet should be on the side closest to the stationary panel.**

**12** Adjust the door using the overlap of the hinge jamb over the wall jamb and the stationary panel into the corner post, if applicable. Plumb the door as best as possible ensuring that there is an *even gap* between the bottom of the door glass and the bottom snap-in filler. Be sure that the stationary panel is inside the corner post by a minimum of a 1/4" or the glass to glass corner overlap is tight, the hinge jamb overlaps the wall jamb by a minimum of 5/16" and the snap-in fillers are tight against the hinge jamb and the exposed glass edge of the stationary panel.

From the inside of the enclosure, mark the location of the hinge jamb on the wall jamb with a pencil at the top and bottom once the door has been properly adjusted.

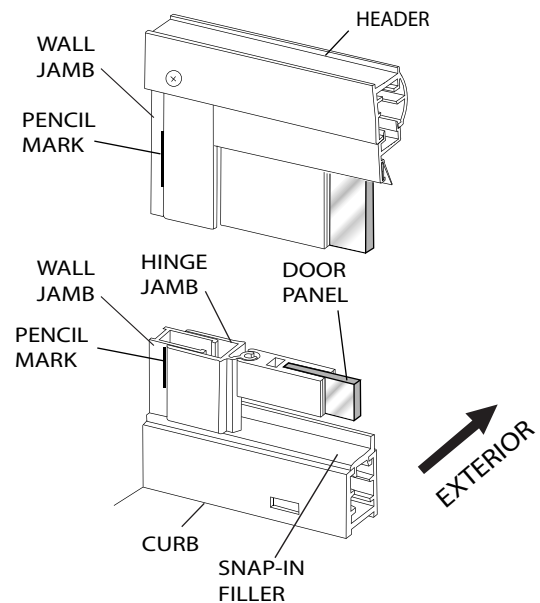

**13** Verify that the door has not shifted using the pencil marks. Then, from the inside of the enclosure, drill two 1/8" holes through the hinge jamb and into the wall jamb approximately 1" from the ends of the jambs at the top and bottom and 3/16" from the edge of the open side of the hinge jamb (see illustration). Drill a third hole in the middle of the jamb in line with the first two and centered between them. Be sure that the drill bit does not go through the front of the enclosure. Carefully, enlarge the three holes in the *hinge jamb only* with a 3/16" drill bit for clearance of the truss head screws. **CAREFUL: DO NOT** enlarge the holes in the wall jamb.

Attach the hinge jamb permanently with three #8 x 1/4" truss head screws.

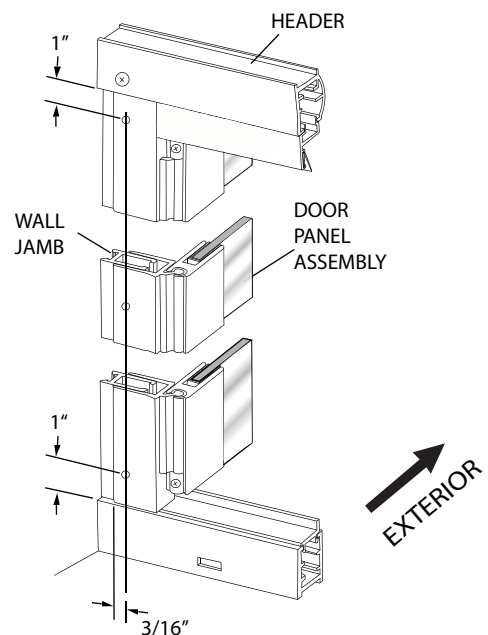



## 14 Grab the remaining vinyl pieces from Step #10.

Cut the pieces of the vertical vinyl [K] 1" longer than the vertical opening. Remove the tape from the glass. Starting on the exterior, slide one end of the vertical vinyl up into the header and press into the wall jamb about 6" down.

Apply light pressure against the interior of the glass panel to hold vinyl in place and install vinyl on the interior in a similar fashion. Press the vinyl into the wall jamb alternating between the interior and exterior.

Repeat the above steps for the corner post, if applicable.

**Caution:** Do not stretch the vinyl when pressing into place and keep the glass pushed against the snap-in fillers.

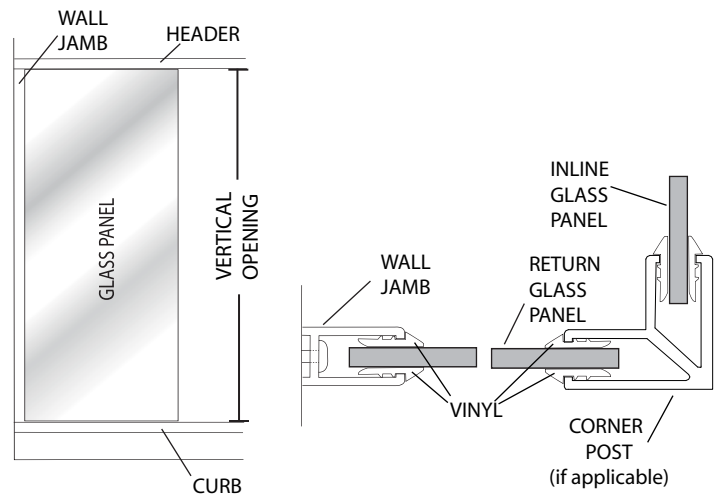

## 15 Remove the small pieces of vinyl installed in Step #9.

Cut four (4) pieces of the horizontal vinyl [L] 1/2" longer than the horizontal opening for both glass panels. Cut the end of each piece of vinyl where it meets the wall jamb with a back mitre (see illustration). This will allow it to sit tight against the face of the vertical vinyl. Cut the other end of each vinyl piece square so it will sit tight against the side of the strike snap-in filler.

Starting at the top on the exterior, place the vinyl against the glass (open side of the crescent shape against the glass) and press into the header at both corners. Continue pressing the vinyl into the header from both ends working towards the middle. Be sure that the glass is centered in the header or the vinyl might fall out until the interior vinyl is installed.

Repeat for the top interior vinyl and then both bottom vinyl pieces.

**Caution:** Do not stretch the vinyl when pressing into place and keep the glass pushed against the snap-in fillers.

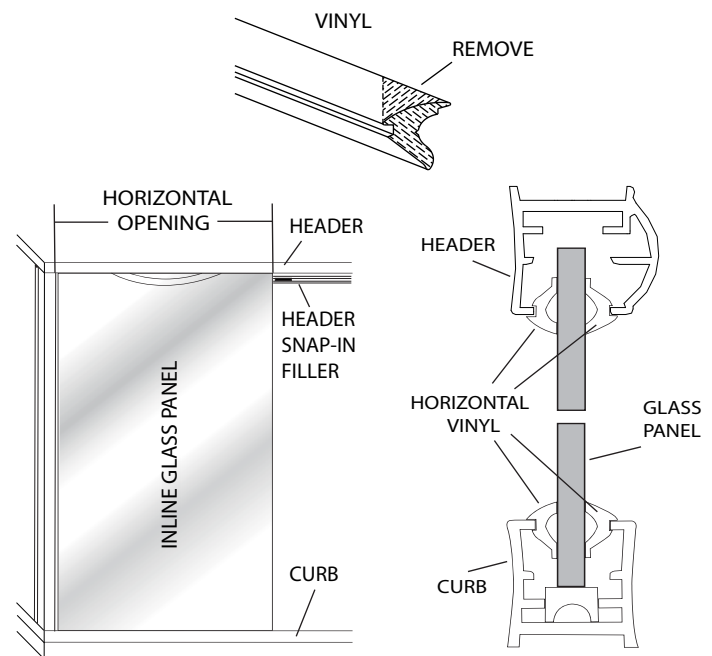

\*\* Glass to glass corner: Miter the end of the vinyl that meets the back wall jamb vinyl. Insert in into the header and work your way around the corner. Trim the vinyl flush with the end of the snap-in fillers.

## 16 Measure the exposed glass edge of the stationary panel (between top & bottom snap-in fillers). Cut the polycarbonate strike jamb [R] to that measurement.

Carefully press the strike jamb over the edge of the stationary panel. Pull the bottom glazing vinyl back from the snap-in filler so the strike jamb will sit on top of the snap-in filler. Re-install the vinyl after the strike jamb is in place.

**TIP:** For the best results, cut the strike jamb on the end that would be at the bottom.

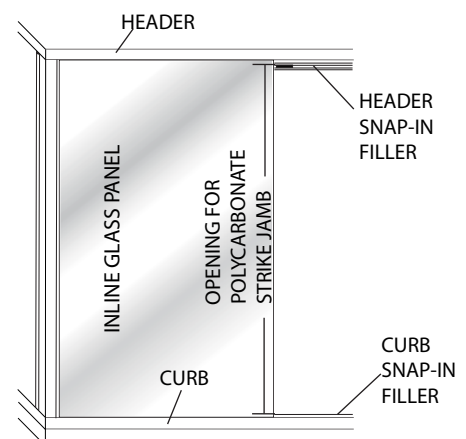

**17** Remove the magnet and slide the vinyl partially out of the header snap-in filler. Trim enough of the vinyl so that the magnet is not covered by the lip of the polycarbonate strike jamb (approximately 3/8" should suffice). Slide the vinyl back into the filler and replace the magnet. Place a small amount of silicone at the end of the magnet to hold in place.

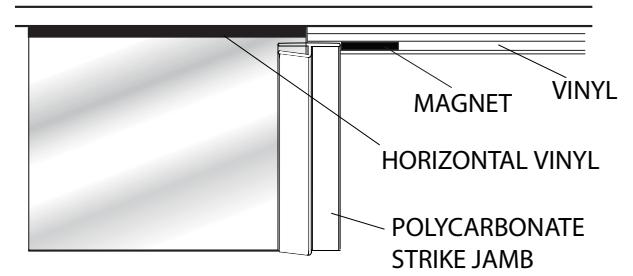

**18** Fold the vinyl material [S] over the top edge of the glass lining it up with the magnet. Mark the two ends of the magnet onto the vinyl with a pencil. Carefully drive the latch [T] onto the door panel using a rubber or plastic mallet.

Close the door and check for proper operation of the latch and magnet. (If adjustment is needed, use a rubber or plastic mallet and a wood block and lightly tap into place). Trim the excess vinyl off with a utility knife.

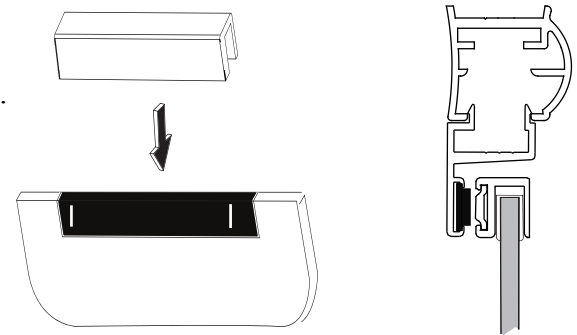

**NOTE: NEVER hit the door latch with a metal hammer!!**

**19** See supplement sheets for installation of the pull handle or the pull/towel bar combination [U].

**20** **NOTE:** The clear vinyl sweep [V] is notched on both ends. Installation depends on the hinge side.

With the door in the open position, slide the sweep onto the bottom of the door with the deflector lip on the interior and the notched side under the hinge rail [M2] of the door assembly.

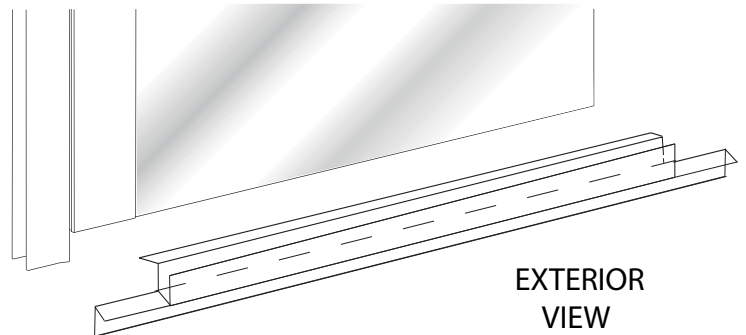

**21** Mark on the sweep the strike edge of the glass with a pencil.

Remove the sweep from the door and cut the it even with the strike edge of the glass.

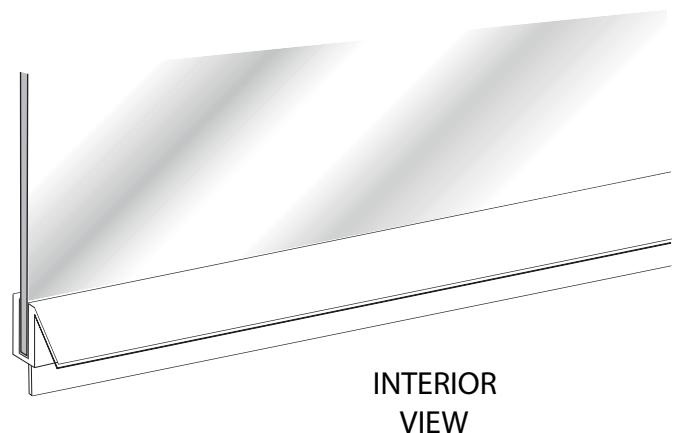

**22** Place the sweep back onto the bottom of the door. Step inside the shower and close the door. Mark on the sweep at the edge of the polycarbonate strike jamb.

Open the door and remove the sweep. Trim the deflector lip and the inside portion of the sweep.

Replace the sweep and close the door. Check for clearance. The lip of the strike jamb should touch the glass not the sweep. (see illustration)

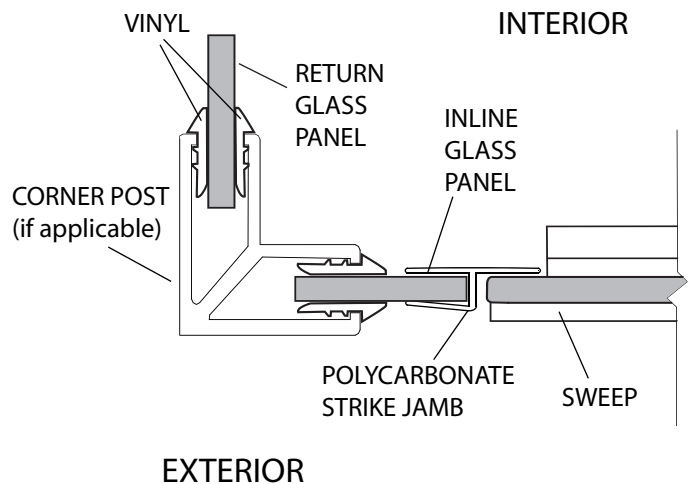

**23** Carefully silicone the seam between the walls and the wall jambs as well as the curb and threshold on the inside of the shower.

**\*\*Glass to glass corner:** Run a bead of silicone on the interior seam where the two glass panels meet. Use tape stretched around the outside to hold the corner tight until the silicone cures.

**NOTE:** Silicone on the exterior seam is optional.

**DO NOT USE** the shower until the silicone is completely cured. Check the tube of silicone for the manufacturer recommended cure time. (typically 24 - 48 hours)

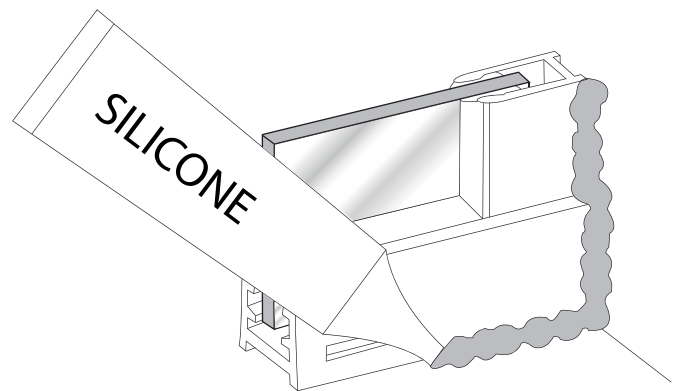

**NOTE: Do not** silicone over the weep holes

**24** Peel off the backing on the BASCO decal [W] and apply it to the inside surface of the header.

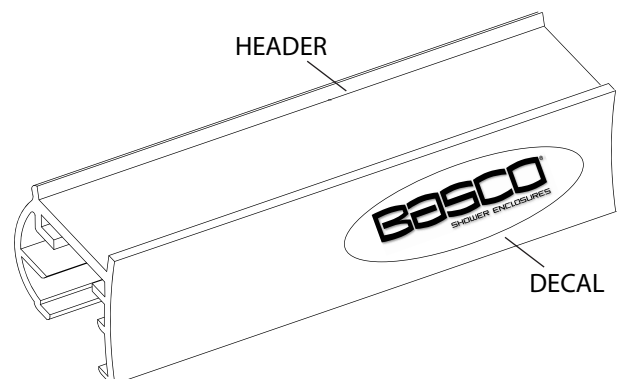

# Back-to-Back Door Pull Installation Instructions

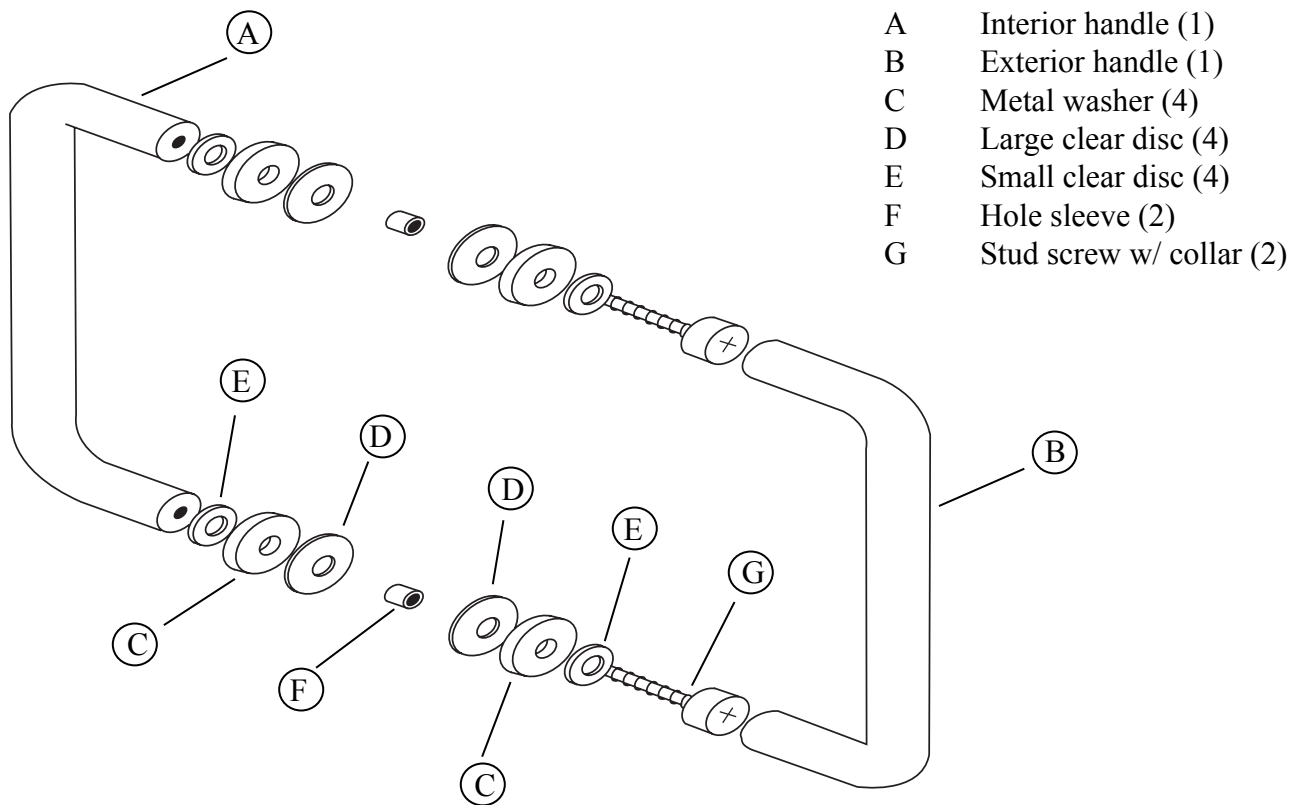

- STEP 1** Using the provided Allen wrench, loosen the two set screws located on the under side of one of the handles near the washers. Separate the handle from the stud screws and collars.
- STEP 2** Using a Phillips-head screwdriver, loosen and carefully remove the stud screws, collars, clear discs and glass hole sleeve from the other handle.
- STEP 3** Remove the interior metal washer, large and small clear disc from the stud screw, leaving the exterior washer, clear discs and hole sleeve on the stud screw with the collar. Careful not to lose any of the pieces.
- STEP 4** From the outside of the door, push the stud screw with collar through the hole in the glass. Be sure the hole sleeve is between the threads of the screw and the glass.
- STEP 5** From the inside of the door, slide the large clear disc onto the screw. Next, slide the metal washer then the small clear disc over the screw. Finally, thread the screw into the interior handle (the one with the smaller threaded holes). Don't tighten. Install the other stud screw with collar and washers through the other handle hole in the glass. After both stud screws are threaded into the interior handle, hold in position and tighten the stud screws with a Phillips-head screwdriver pulling the interior handle tight to the glass.
- STEP 6** From the outside of the door, position the exterior handle over the collars of both stud screws and tighten the set screws with the Allen wrench.

# “C” Pull Handle / Towel Bar Combination Installation Instructions

There are eleven hardware components for the Combination Door Pull and Towel Bar mounting: One pull; one towel bar; two end caps with threaded studs; one stud head screw; and six clear gaskets to act as a buffer between the hardware and the glass.

**STEP 1** Take the stud head screw and both end caps with a stud protruding and sleeve a clear gasket on each of the screws.

**STEP 2** The towel bar will be mounted first. Take the stud head screw with the washer and gasket attached. From the inside of the enclosure, push the threaded portion through the top hole in the glass on the strike side of the door. Place a clear gasket over the stud head screw on the outside of the glass door. Now thread the stud screw into the towel bar and tighten. On the other end of the towel bar (on the hinge side), push one of the end caps with the stud protruding through the hole. Now place a clear gasket over the threaded stud on the outside of the glass door. Thread the end cap into the towel bar and tighten by hand. Tighten the stud head with a screwdriver and the end cap by hand.

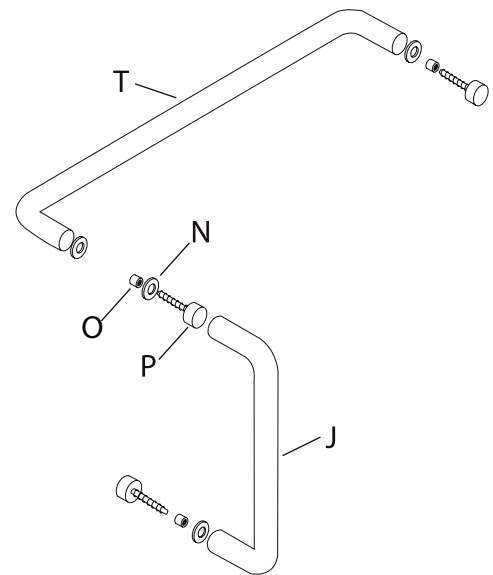

J	Exterior handle	(1)
T	Towel bar	(1)
N	SC4586 Small clear discs	(6)
O	SC4587 Glass hole sleeve	(3)
P	SCR1588 Stud screws	(3)

**STEP 3** The towel bar is now complete. Now it is time to mount the pull portion. From the outside of the enclosure, push the end cap with the stud protruding through the bottom hole of the door. First place a clear gasket over the threaded stud on the inside of the glass door. Now thread the stud into the small threaded opening of the pull. Do not tighten this end of the pull down at this time. Place the end of the pull with the large hole and the set screw over the stud head. Now tighten the end cap by hand as tight as possible. Use the Allen wrench provided to tighten the set screw on the pull to the stud head screw.