



INSTALLATION INSTRUCTIONS



UNIT No. 8150/9150 SHOWER ENCLOSURE



MAINTENANCE: Two primary materials are used to manufacture your new Basco enclosure: tempered glass and anodized aluminum. To assure a long lasting finish on the enclosure, wipe it down with a towel after each use. Never use a scouring agent to clean the aluminum.

For occasional, more concentrated cleaning efforts, we find that *Lysol Bathroom Cleaner* works extremely well. Be sure that any over spray falling on the aluminum frame is rinsed thoroughly and dried. Many over-the-counter cleaners, if applied to the aluminum and left on, will harm the metal finish and cause permanent damage, even though their directions indicate safe use on shower doors.

INSTALLATION NOTES: Unpack your unit carefully and inspect for freight damage. Lay out and identify all parts using the instruction sheets as a reference. Before discarding the carton, check to see that no small hardware parts have fallen to the bottom of the box. If any parts are damaged or missing, refer to the descriptions noted in the instructions when contacting your dealer for replacements.

Handle the glass panels carefully and protect the edges.

Please wear safety glasses whenever drilling or cutting. When drilling holes in the ceramic tile or marble, use a center punch and hammer to carefully break the surface glaze so the drill can start without skidding.

To install your BASCO Shower Door you will need the following: tape measure, level, #2 Phillips screwdriver, 3/16" wrench, drill, 1/8" and 3/16" drill bits, hacksaw, pencil, and caulking (clear silicone recommended). Optional tools include a miter box for cutting parts to length, files, center punch, and masking tape.

NOTE: Tempered glass cannot be cut.

Although safety tempered glass is very resistant to breakage, the glass can still break if unequal pressure is placed on it during installation. Use caution. In addition, the sharp corners of the panels can damage tile and floor surfaces, so it is best to handle the glass panels carefully and protect the edges.

8150/9150 PARTS LIST

- | | |
|------------------------------------|---------------------------------------|
| A. 1 Tub Track with Vinyl | L. 2 Towel Bar Brackets |
| B. 2 Wall Jambs | M. 2 Towel Bars |
| C. 6 Plastic Wall Anchors | N. 2 #10-24 x 7/8" Truss Head Screws |
| D. 6 #8 x 1 1/2" Truss Head Screws | P. 2 #10-24 x 1 1/8" Flat Head Screws |
| E. 2 Nylon Spacers | R. 2 Acrylic Finger Pulls |
| F. 1 Header | S. 2 Basco Decals |
| G. 2 Glazed Panels | T. 1 Nylon Bottom Guide |
| H. 4 Nylon Roller Bearings | U. 1 #6 x 3/8" Pan Head Screw |
| J. 4 #8-32 x 3/8" Hex Head Screws | V. 2 Stainless Bumper Inserts |
| K. 4 Towel Bar Trim Rings | W. 2 Soft Jamb Bumpers |

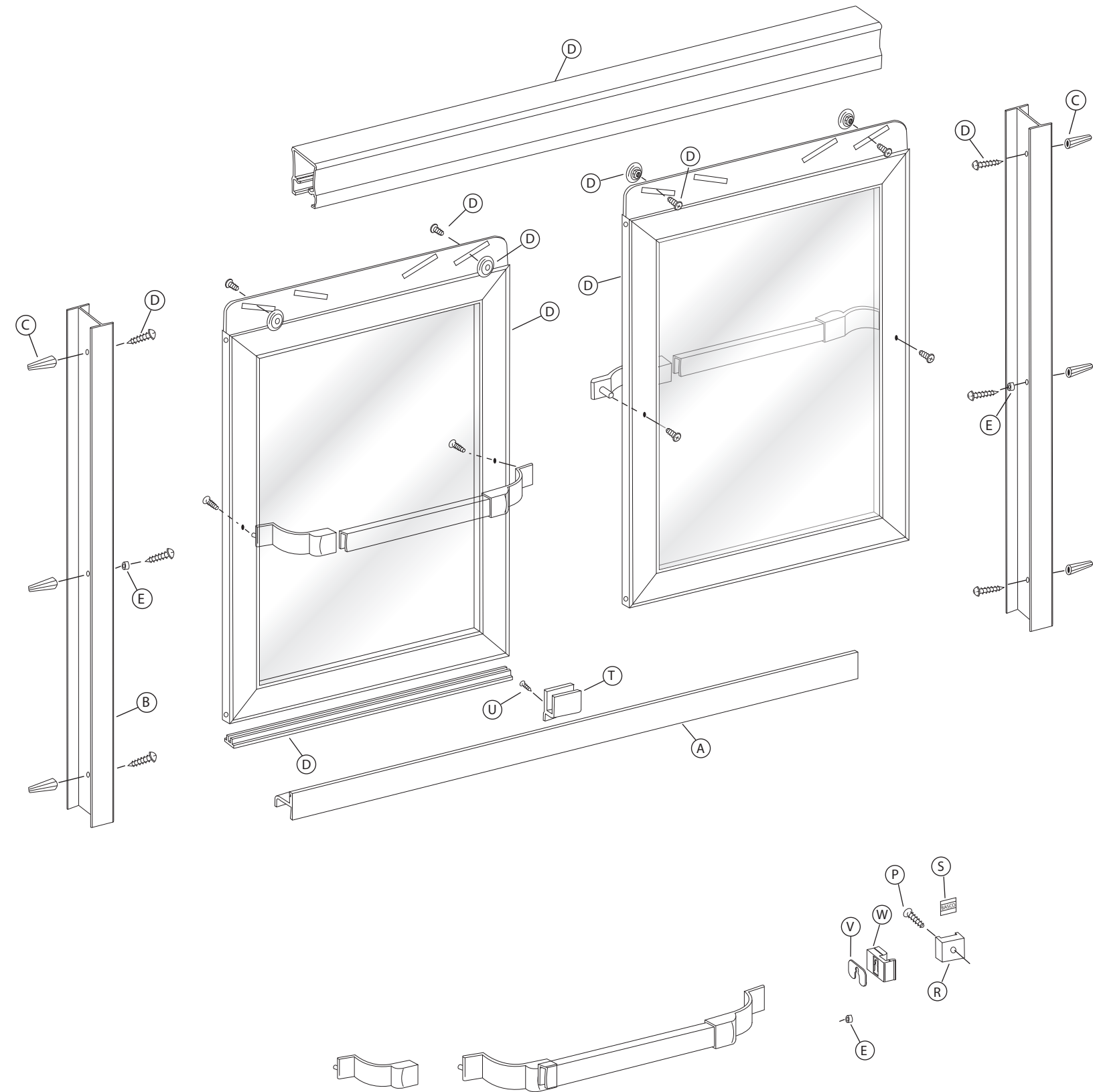

1 Measure the wall-to-wall opening at the center of the tub rim. Cut the tub track [B] 1 1/8" short of this dimension. An inexpensive miter box (available at your local hardware store) will help you get clean square cuts.

Position the tub track in the center of the tub rim leaving an equal amount of space between the end of the track and the wall. Mark the position of the track with a pencil and use short strips of masking tape to hold the parts in place temporarily.

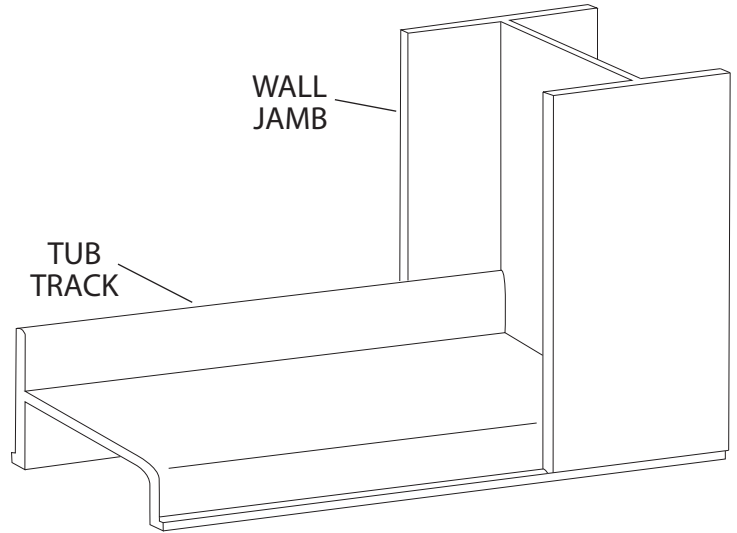

2 Use a level to plumb both wall jambs [B] and mark the pre-drilled hole locations on the wall. Lightly mark along both sides of the tub track [A] with a pencil and remove all parts.

For tile or marble walls, drill six 3/16" diameter holes and insert the plastic wall anchors [C]. Attachments to fiberglass or acrylic units can be made in two ways. If reinforcement is built into the wall of unit, drill six 1/8" diameter holes to install mounting screws directly into the reinforcement. If walls are not reinforced, drill six 3/16" holes and install plastic wall anchors or Molly bolts (Molly bolts not supplied by Basco).

CAUTION: The track should never be screwed to the tub. This will damage the tub and cause leakage.

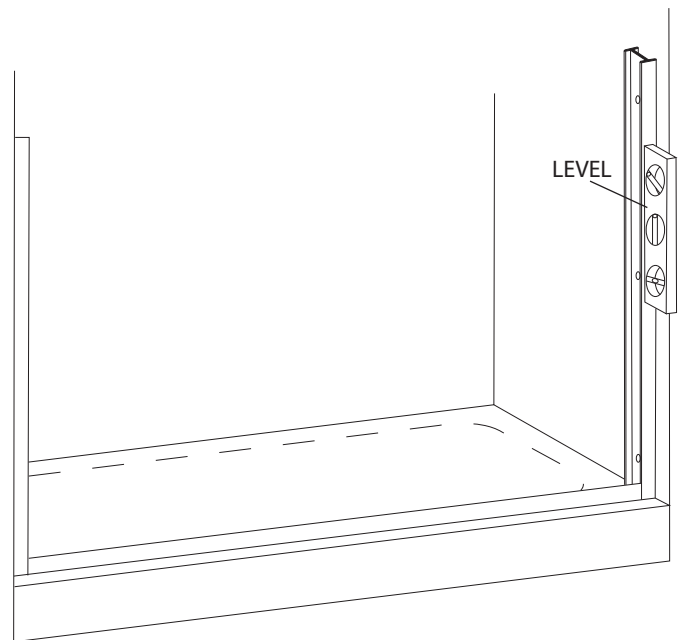

3 Before replacing the tub track [A], gently force a slight downward bow in the extrusion. This will ensure the track fits tight to the tub. Caulk the bottom legs of the tub track as shown and replace in the exact position marked in Step #2.

NOTE: Improper caulking will result in leaks.

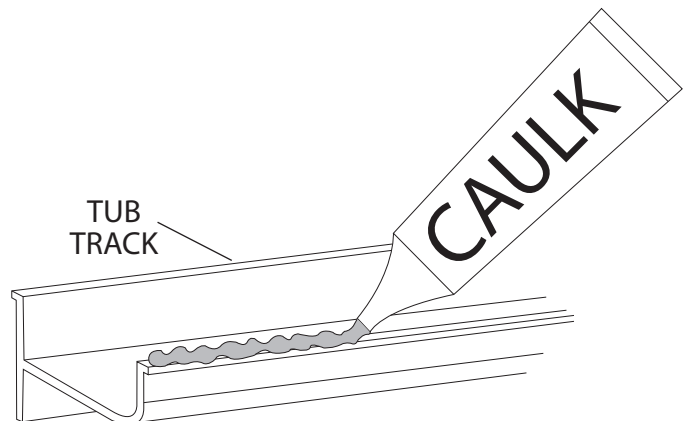

4 Measure the wall-to-wall opening at the top of the wall jambs and cut the header 1/16" short of this dimension. Place the header over both jambs. Drill two 7/64" holes through the header and into the wall jambs on the inside face. Attach with two #5 x 3/8" pan head screws.

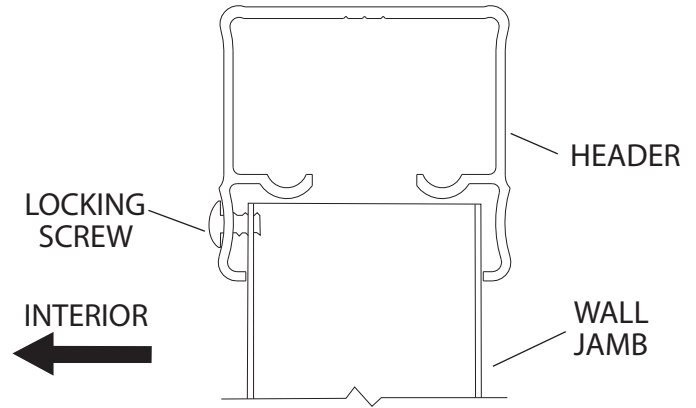

5 Attach two rollers to the interior panel using two #8-32 x 3/8" hex head screws centered in the punched slots, lift interior panel into place. Repeat for exterior panel.

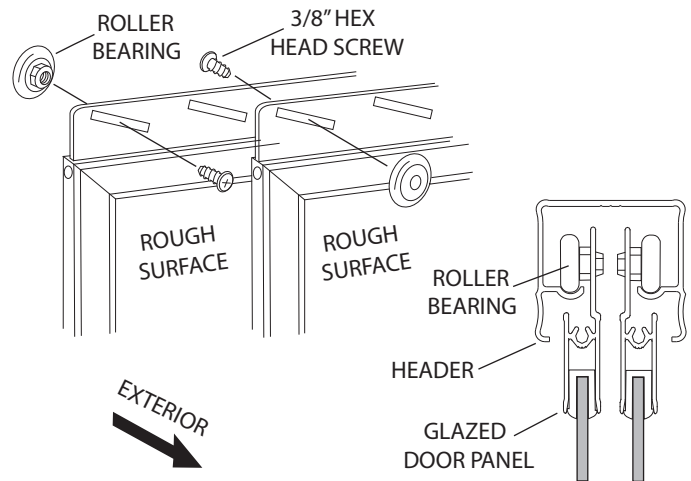

6 Place the towel bar between the two towel bar brackets. Attach the two towel bar brackets to the exterior door panel with two truss head screws. Repeat for the interior door panel.

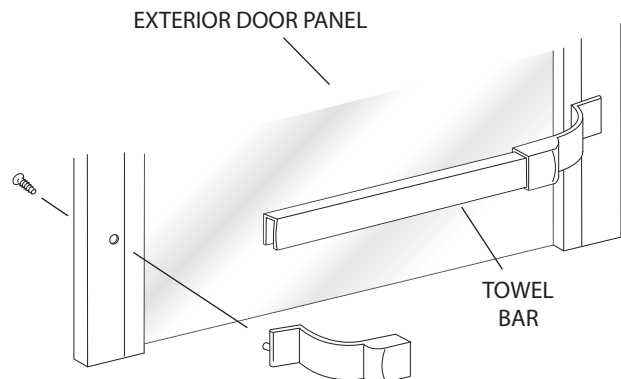

7

If door panels are not parallel to the wall jambs, remove and adjust rollers up or down to compensate. Slide both panels to one side of opening. Center panel guide on track under interior door panel as shown. Using the hole in the panel guide, drill a 7/64" hole into the track. Attach panel guide with a #6 x 3/8" truss head screw.

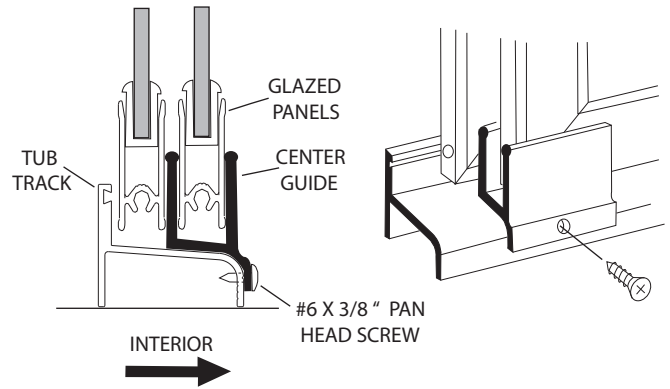

8

Caulk both ends of the track where it meets the wall jambs and the interior edges of the wall jambs as shown. Allow caulking to dry at least 24 hours before

