



INSTALLATION  
INSTRUCTIONS

# UNIT No. 160/760 THIN-LINE SHOWER ENCLOSURE



**MAINTENANCE:** Two primary materials are used to manufacture your new Basco enclosure; tempered glass and anodized aluminum. To assure a long lasting finish on the enclosure, wipe it down with a towel after each use. Never use a scouring agent to clean the aluminum.

For occasional, more concentrated cleaning efforts, we find that Lysol Cleaner works extremely well. Be sure that any over spray falling on the aluminum frame is rinsed thoroughly and dried. Many over-the-counter cleaners, if applied to the aluminum and left on, will harm the metal finish and cause permanent damage, even though their directions indicate safe use on shower doors.

**INSTALLATION NOTES:** Unpack your unit carefully and inspect for freight damage. Lay out and identify all parts using the instruction sheets as a reference. Before discarding the carton, check to see that no small hardware parts have fallen to the bottom of the box. If any parts are damaged or missing, refer to the descriptions noted in the instructions when contacting your dealer for replacements.

Handle the glass panels carefully and protect the edges.

Please wear safety glasses whenever drilling or cutting. When drilling holes in the ceramic tile or marble, use a center punch and hammer to carefully break the surface glaze so the drill can start without skidding.

To install your BASCO Shower Door you will need the following: level, tape measure, #2 Phillips screwdriver, drill, 1/8", 7/32" and 3/16" drill bits, 3/16" wrench, hacksaw, mallet or hammer, wood block, razor, pencil, glass cleaner, and caulking (clear silicone recommended). Optional tools include a miter box for cutting parts to length, files, center punch, and masking tape.

**NOTE: Tempered glass cannot be cut.**

**Although safety tempered glass is very resistant to breakage, the glass can still break if unequal pressure is placed on it during installation. Use caution. In addition, the sharp corners of the panels can damage tile and floor surfaces, so it is best to handle the glass panels carefully and protect the edges.**

**160/760 THIN-LINE  
PARTS LIST**

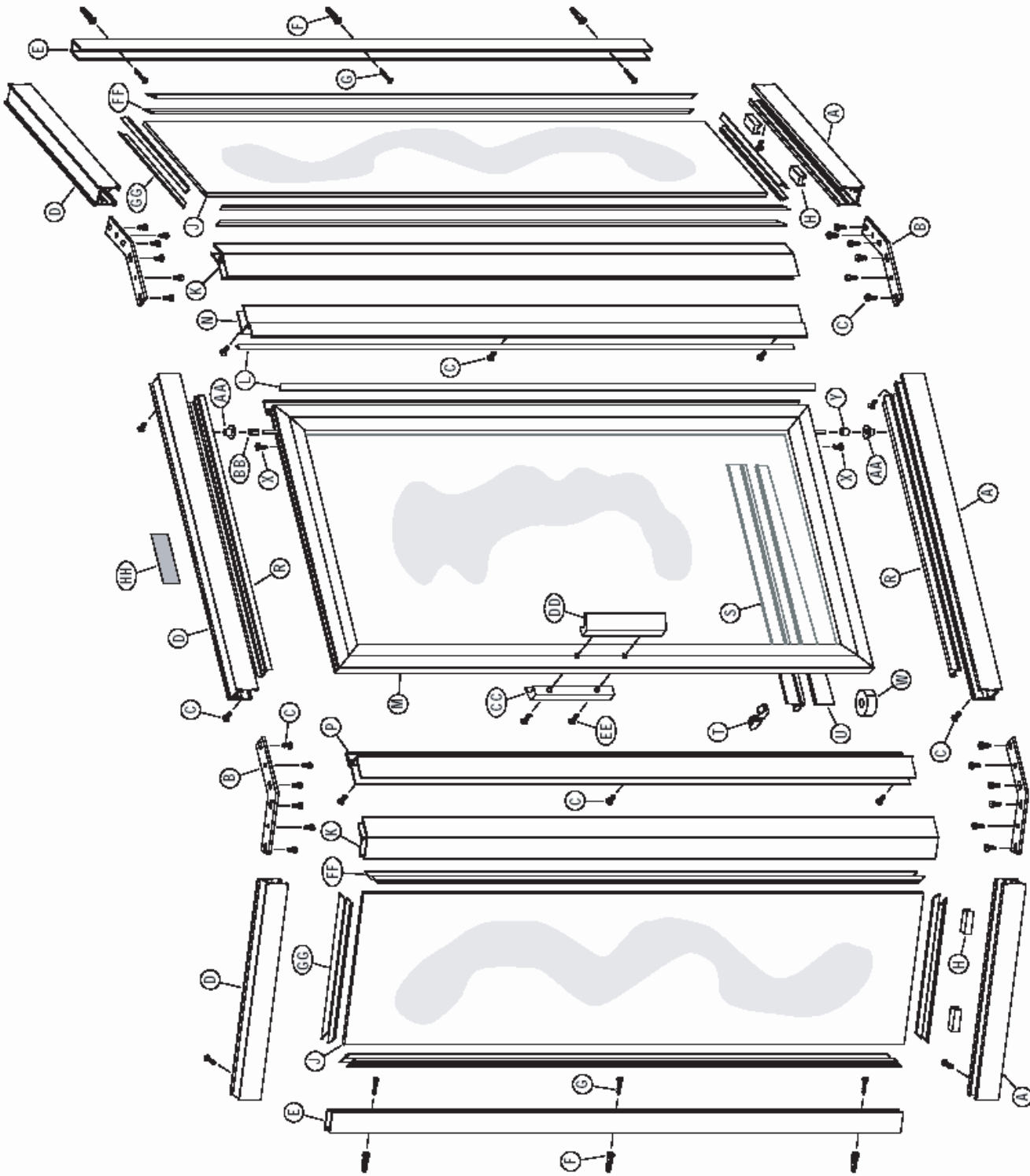

- A. 3 Curb Sections
- B. 4 135° Anchor Plates
- C. 40 #8 x 1/4" Truss Head Screws
- D. 3 Header Sections
- E. 2 Wall Jamb
- F. 6 Plastic Wall Anchors
- G. 6 #8 x 1 1/2" Truss Head Screws
- H. 4 Plastic Setting Blocks
- J. 2 Fixed Glass Panels
- K. 2 135° Posts
- L. 2 Clear Vinyl Jamb Seals
- M. 1 Glazed Door Panel
- N. 1 Pivot Jamb
- P. 1 Strike Jamb (Magnetic)
- R. 2 Snap-in Fillers
- S. 1 Drip Rail
- T. 2 Drip Plugs
- U. 1 Tapered Drip Vinyl
- W. 1 Roll Double Stick Tape
- X. 2 #10 x 7/16" Sq. Head Set Screws
- Y. 1 Nylon Spacer
- AA. 2 Nylon Pivot Bushings
- BB. 1 Security Washer
- CC. 1 Interior Door Handle
- DD. 1 Exterior Door Handle
- EE. 2 #6 x 1 1/4" Round Head Screws
- FF. 8 Pos. Vertical Glazing Vinyl (72")
- GG. 4 Pcs. Horizontal Glazing Vinyl (72")
- HH. 1 Basco Decal

**1** The BASCO 160/760 Thin-Line Shower Enclosure is completely reversible and may be installed pivot-left or pivot-right. For maximum waterproofing, the pivot jamb should be opposite the shower head. Use the diagram to determine the correct position for the door in your particular Thin-Line installation. This instruction sheet depicts a pivot-right installation.

NOTE: Fixed glass panel size should be determined by formulas shown on BASCO detail sheets.

**CAUTION:** For safety reasons, the door panel must always open *outward*.

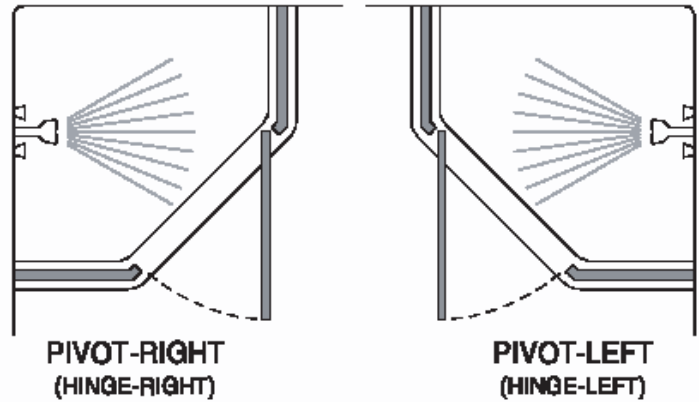

**2** NOTE: If the header and curb are already assembled, proceed to Step #3.

Assemble the three curb sections [A] (with weep slots) by sliding two 135° anchor plates [B] into the mitered ends and forcing the sections together. The weep slots in the curb must be to the inside. Using the slotted holes in the anchor plates as a guide, drill matching 1/8" holes into the curbs. Secure the anchor plates to the curbs with eight #8 x 1/4" truss head screws [C]. As you tighten the screws, be sure the mitered ends are forced tightly together.

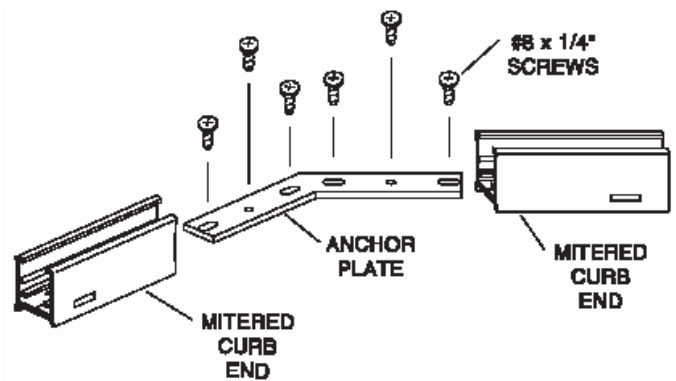

Assemble the three header sections [D] in the same manner and set the assembly aside.

**3** The curb should sit near the centerline of the sill. If required, use a file to round the lower ends of the curb assembly to fit the shower sill properly.

Using a 3/16" drill bit, drill the interior face of the curb assembly on both ends as shown. These holes may be predrilled from the factory.

Reposition the curb assembly on the shower sill and mark its position with a pencil line along the interior and exterior base.

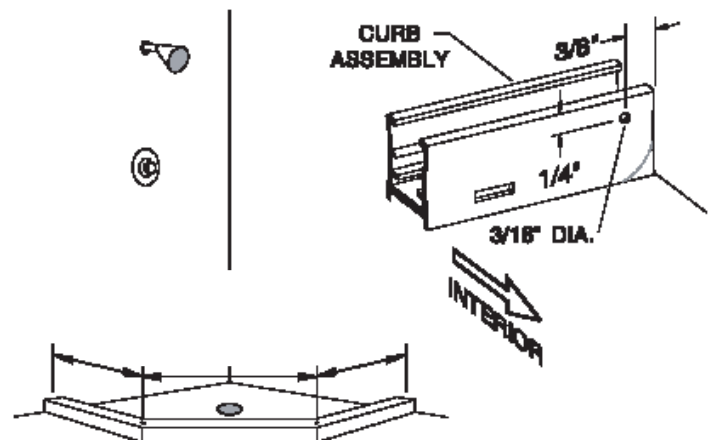

## 4

Place the two wall jambs [E] into the ends of the curb assembly [A]. Masking tape may be used to hold the curb in place during this operation. Plumb the jambs and mark the hole locations on the wall. Remove all parts and drill the walls for mounting hardware.

For tile or marble walls, drill six 7/32" diameter holes and insert the plastic wall anchors [F]. A center punch helps locate the holes accurately.

Attachments to fiberglass or acrylic units can be made in two ways. If reinforcement is built into the wall of unit, drill three 1/8" holes to install mounting screws directly into the reinforcement. If walls are not reinforced, drill 7/32" holes and install plastic wall anchors or toggle bolts (toggle bolts not supplied by BASCO).

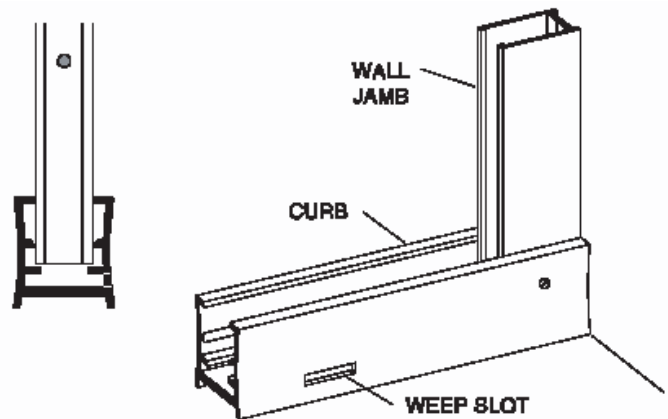

## 5

Wipe the shower walls and sill, curb assembly [A] and wall jambs [E] with a clean, dry cloth to remove any dust or debris. Apply a 1/4" bead of caulk along the inside of both of the pencil lines marked in Step #3. Carefully replace the curb in the exact position marked. Caulk the inside of the curb ends where they meet the wall. Caulk around the anchor plates [B], screws [C], and the insides of the mitered joints.

Replace both wall jamb and attach to the walls with six #8 x 1 1/2" truss head screws [G].

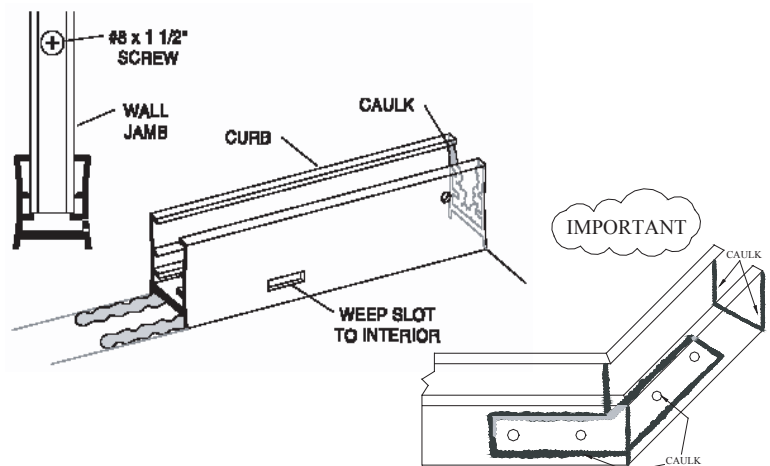

## 6

Place the setting blocks [H] in the curb assembly [A] as shown to support the two fixed glass panels [J]. The setting blocks should be positioned approximately 3" from each corner of the panels. Remove any protective strips from the first glass panel and set it into place. It should rest on the setting blocks and be engaged approximately 1/2" into the wall jamb [E]. A strip of masking tape 1/2" from each vertical edge of the glass will aid alignment.

Press a 135° post [K] into the curb assembly. It should overlap the glass panel by 1/2". Use masking tape to hold the post in position temporarily. Repeat the glass and post installation on the opposite panel.

**NOTE:** To facilitate out of plumb walls, the 1/2" glass bite may be varied from 1/4" to 3/4". **NOTE: IF QUICK-N-STALL OPTION IS ORDERED, THE SETTING BLOCKS ARE NOT NEEDED.**

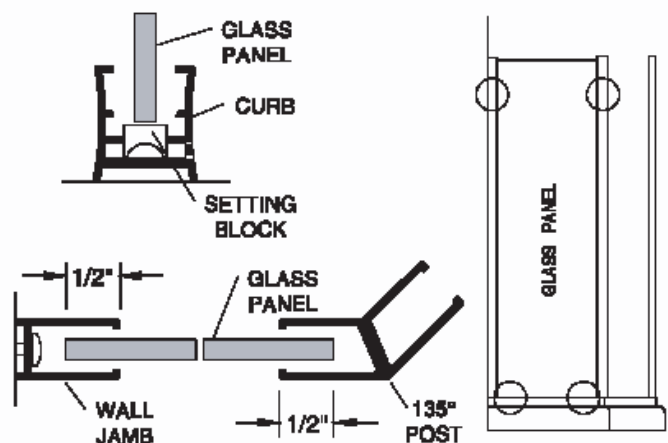

# 7

Using a 3/16" drill bit, drill the interior face of the header assembly on both ends as shown. These holes may be predrilled from the factory.

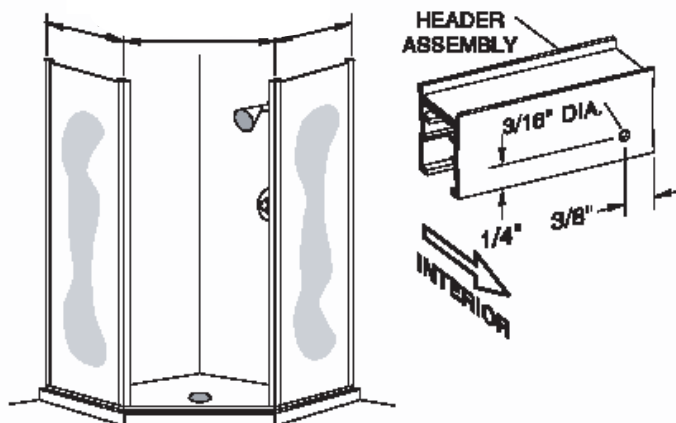

# 8

Press the header assembly [D] over the wall jambs [E] and 135° posts [K]. Check the posts for plumb. Adjust as required by varying the overlap of the header over the wall jambs. You may need to trim the ends of the header where it meets the wall. The minimum horizontal dimension for the door opening is the door panel width (see the graphic in Step #9) plus 1/2", maximum is the door panel width plus 1 3/4".

Using the holes in the ends of the header and curb as a guide, drill four 1/8" holes into the wall jambs. Drill four holes thru the header and curb into the two posts as shown, then enlarge the outer holes with a 3/16" drill for clearance on the self-tapping screws. Secure the header and curb to the wall jambs and posts with eight #8 x 1/4" truss head screws [C].

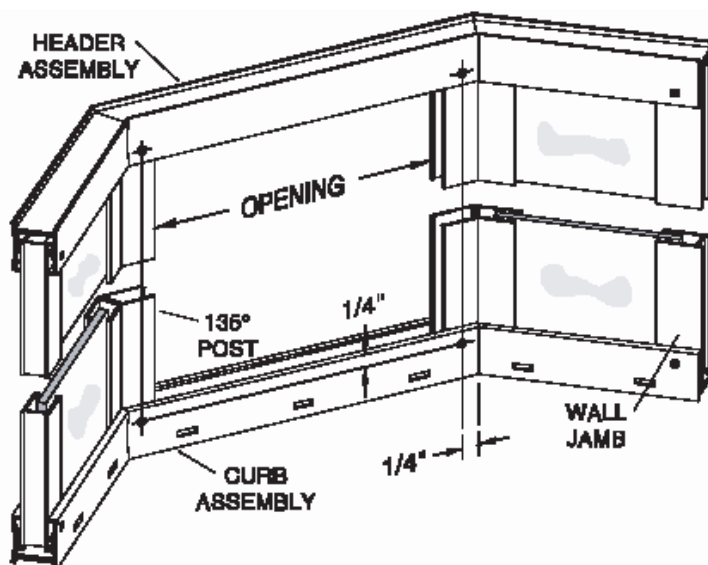

**CAUTION:** Slide glass panels [J] away from the jambs before drilling to prevent damage or breakage.

# 9

Strip two clear vinyl jamb seals [L] into the door panel [M] splash guard and the pivot jamb [N] and trim flush at both ends. Both vinyls should be turned to trap water from the shower head. Secure the vinyls with a small quantity of glue or caulk at each end or by carefully crimping the vinyl pocket. Set the door panel aside. Press the pivot jamb and strike jamb [P] (with magnetic strip) over the two 135° posts [K]. Refer to Step #1 for the proper handling of the door.

**NOTE:** The magnetic strip on the strike jamb must face the exterior and the clear vinyl jamb seal on the pivot jamb must face inward.

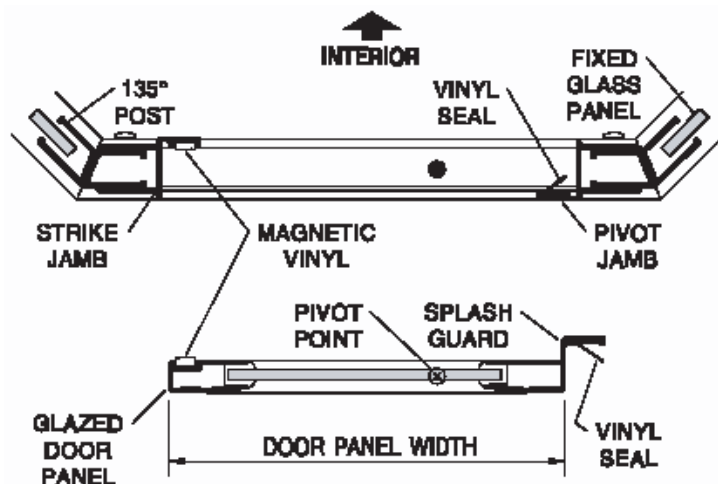



# 10

Snap the fillers [R] into the curb assembly [A] and header assembly [D] between the door jambs with the **RAISED LIP TO THE EXTERIOR** and the pivot holes toward the pivot jamb. Center the curb filler in the curb between the pivot and strike jamb (use masking tape to hold in position).

NOTE: The snap-in-filler should be exactly  $3/8''$  longer than the door panel width.

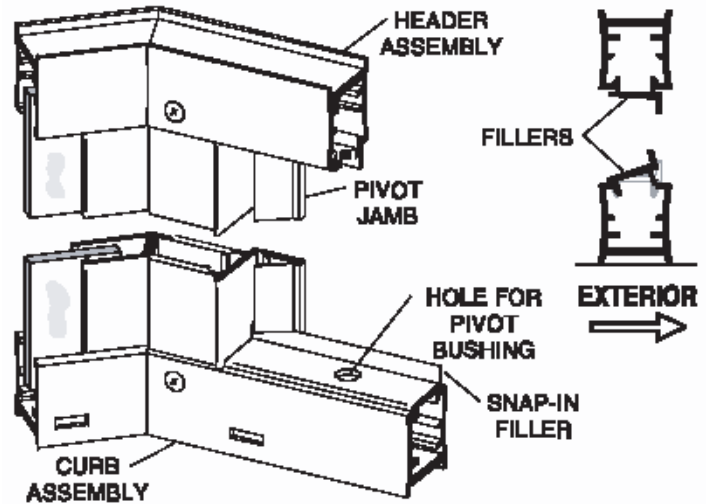

# 11

Pull the bottom end of the pivot jamb [N] tight to the curb filler [R] and plumb the jamb. Drill two  $1/8''$  holes thru the pivot jamb and into the  $135^\circ$  post [K] in line with the screws in the head and curb and approximately  $1/4''$  vertically from the ends of the jamb. Drill a third hole centered between the first two, then enlarge the outer holes with a  $3/16''$  drill for clearance on the self-tapping screws. Attach the pivot jamb permanently with three #8 x  $1/4''$  truss head screws [C].

Slide the header filler [R] tight against the pivot jamb. Push the strike jamb [P] tight against the fillers top and bottom. With the pivot jamb plumb and both fillers tight between the two door jambs, the strike jamb also will be plumb and parallel to the pivot jamb. Attach the strike jamb to the other  $135^\circ$  post [K] in the same manner as the pivot jamb.

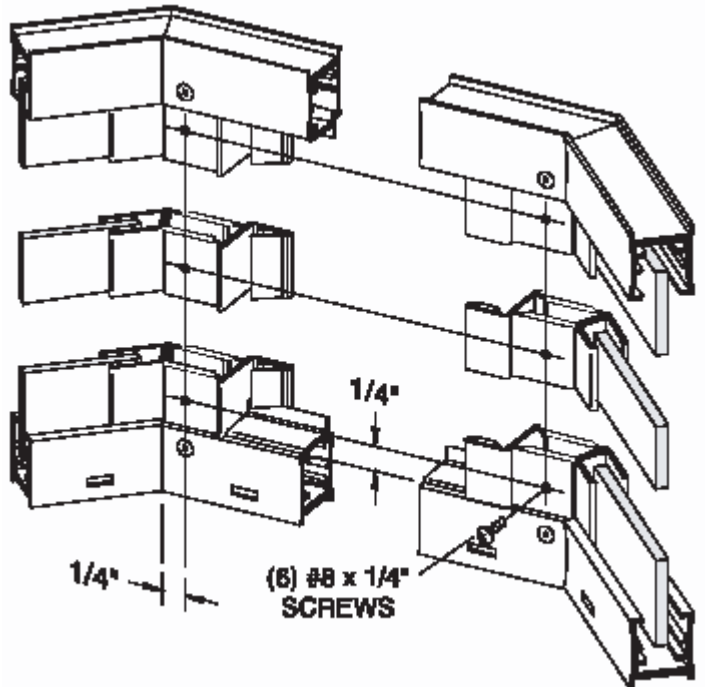

# 12

Clean the bottom door rail and the drip rail thoroughly with rubbing alcohol to ensure proper adhesion. Unroll the double stick tape [W] and carefully apply it to the back of the drip rail (do not peel the tape backing yet).

Insert the tapered drip vinyl [U] into the drip rail. Position the drip rail flush with the bottom and pivot side of the door panel [M], then raise the strike side until the bottom edge of the drip vinyl is parallel to the curb [A]. Mark the location of each end of the drip rail.

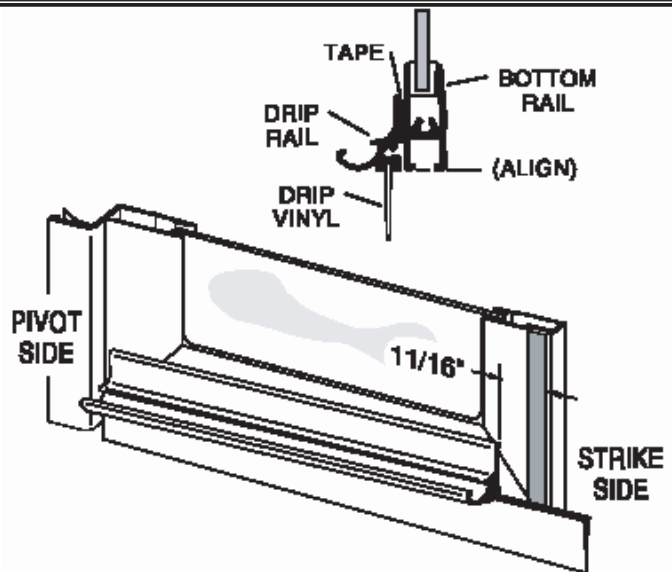

# 13

Insert the two #10-24 x 7/16" square head set screws [X] into the threaded holes in the pivot blocks in the top and bottom rails of the glazed door panel [M]. Position the pivot pins 1 1/2" from the pivot side of the door (the side opposite the magnetic strip). Tighten the set screws just enough to prevent the pivot blocks from moving (finger tight plus a quarter turn). A 3/16" wrench (not supplied by BASCO) will fit the set screw heads.

Press the white nylon spacer [Y] over the bottom pivot pin on the door panel.

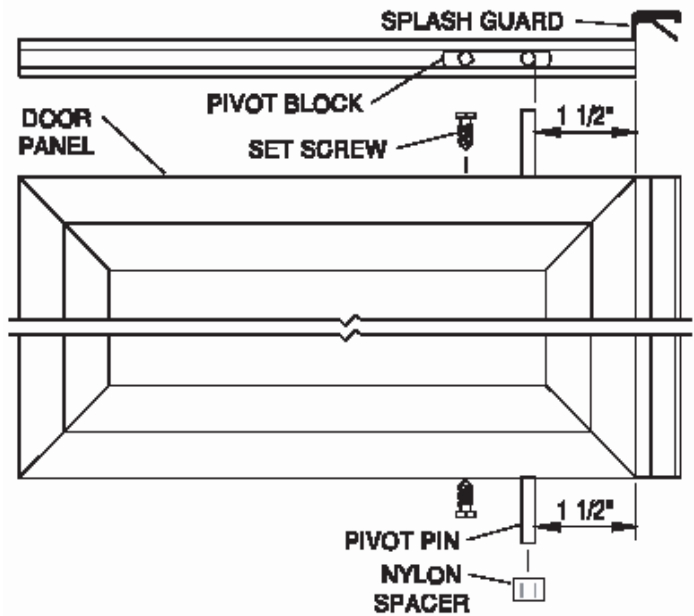

# 14

Adjust the drip vinyl [U] by sliding it left or right until it just touches the curb. Trim the vinyl (flush with the pivot end and notch 1/4" longer than the drip rail as shown on the strike end).

The drip plug [T] is supplied with a left and right hand plug together. Break the right and left drip plug apart and insert the appropriate plug into the high (strike) side of the drip rail. Discard the unused drip plug. Peel off the tape backing and carefully press the drip rail [S] to the door in the marked position.

**NOTE: Cleaners with alcohol content can dissolve the adhesive that attaches the drip rail. To prevent this possibility, place a small bead of clear sealant at the top of the drip rail where it is attached to the bottom rail.**

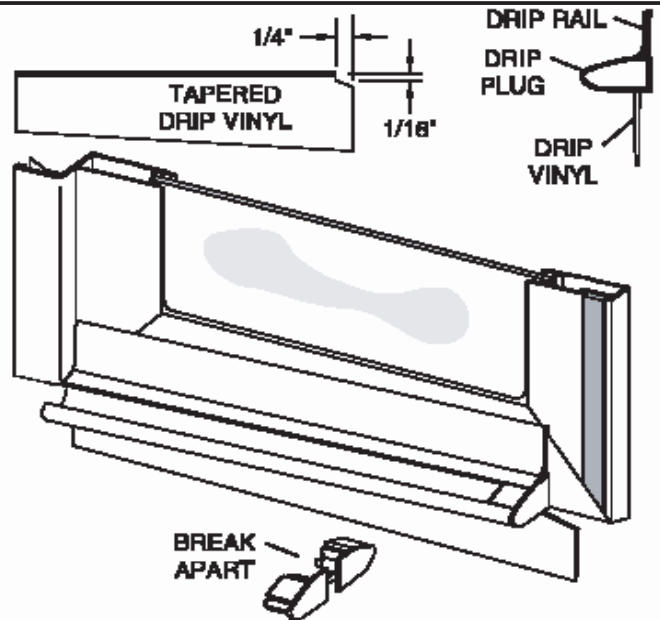

# 15

Insert the two nylon pivot bushings [AA] into the pivot holes in the head and curb fillers [R].

Lift the door panel [M] and insert the top pivot pin into the pivot bushing in the header filler. Hold the door vertical and insert the bottom pivot pin into the pivot bushing in the curb filler. It may be necessary to remove the header retaining the screws and raise the header slightly to install the door.

When the door has been set into place, snap the security washer [BB] over the top pivot pin to hold the upper pivot bushing in place and prevent accidental dislodging of the door.

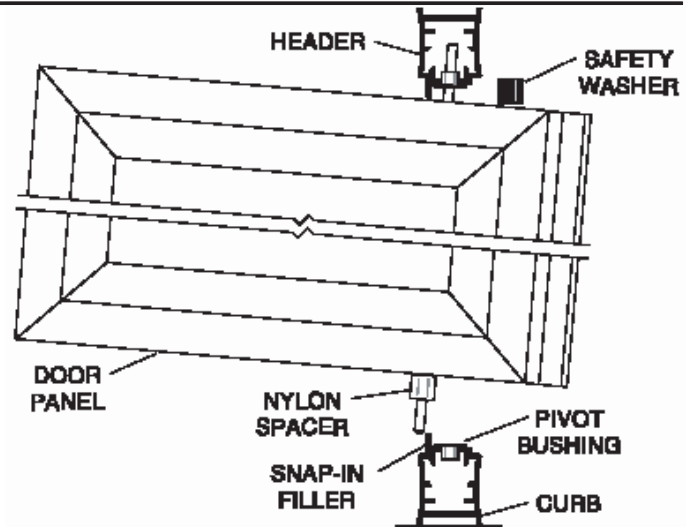



# 16

Attach the interior door handle [CC] and the exterior door handle [DD] to the door panel [M] with two #6-32 x 1 1/4" round head screws [EE].

Close the door and check the clearance with the strike jamb [P]. If necessary, loosen the set screws [X] on the top and bottom slide bars and adjust the door panel to align the strike magnets. When the door panel is properly aligned, tighten the set screws securely.

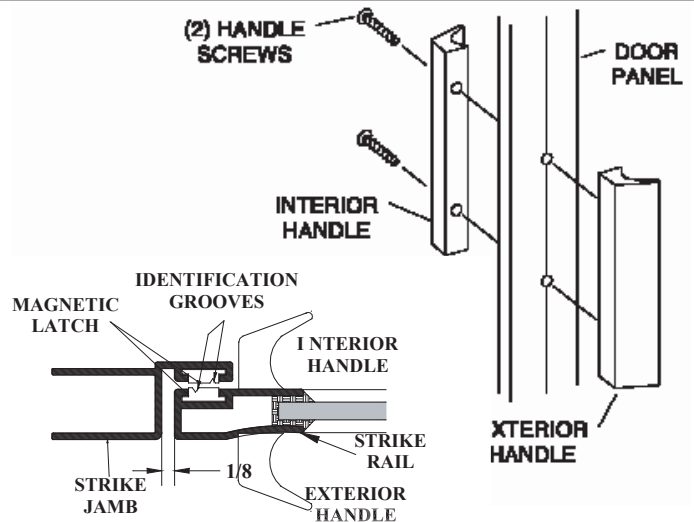

# 17

Inspect the pieces of black glazing vinyl, and note the two different profiles. The smaller shape [FF] is installed vertically and the larger shape [GG] is installed horizontally. For structural strength and maximum water resistance, these vinyls are designed to fit tightly between the glass and framing. To speed installation, use glass cleaner for lubrication and a small block of wood to press the vinyl into place.

FIXED GLASS PANEL	VERTICAL	HORIZONTAL
1/4" GLASS REQUIRES:	V-219	V-220
3/16" GLASS REQUIRES:	V-226 NOTCH	V-225 NOTCH



# 18

Cut eight pieces of the smaller vinyl [FF] 1" longer than the vertical opening (to prevent gapping from shrinkage) and trim the ends on a 45° angle. Using the masking tape guides, center the first glass panel [J] in the frame. Cut four short (1" – 2") pieces of the small vinyl and press into the jamb and post on each side to hold the glass temporarily.

Take one of the long pieces of vinyl, and starting on the outside exterior jamb, press each end into the frame and work toward the middle. Be careful not to stretch the vinyl. Install the other three pieces in a similar fashion.

Repeat for the second glass panel.

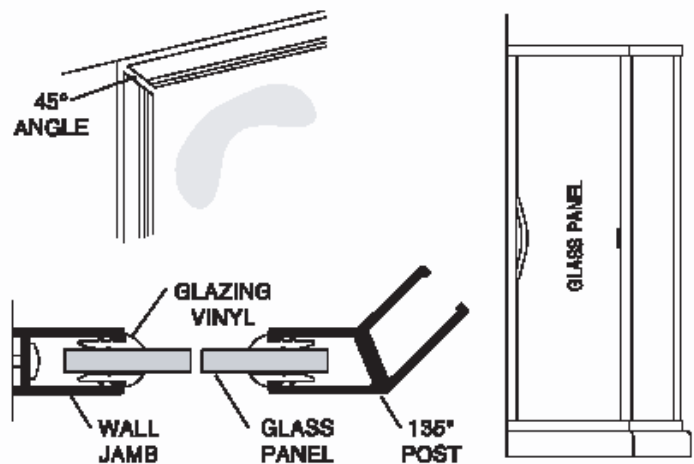

---

---

# 19

Cut eight pieces of the larger vinyl [GG] 1/2" longer than the horizontal opening and trim the ends on a 45° angle. Install the top exterior vinyl starting at both ends and working toward the middle. Be careful not to stretch the vinyl.

Install the top interior vinyl and the two bottom vinyls in the same way.

Repeat for the second glass panel.

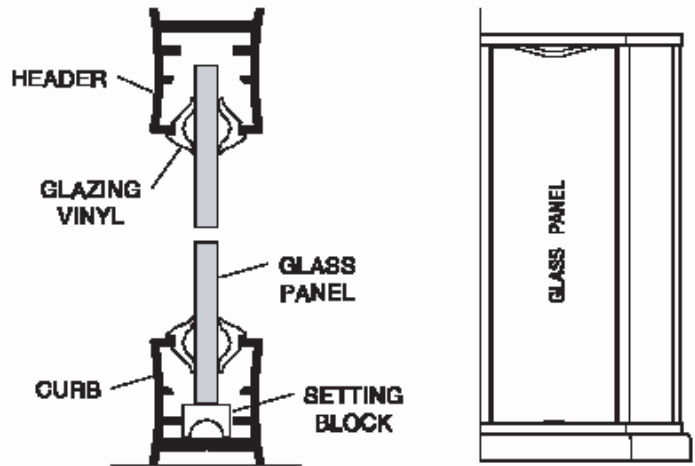

---

---

# 20

Carefully caulk the interior jamb-to-wall and curb-to-base joints. For appearance, you may wish to caulk the exterior joints as well. We recommend you wait twenty-four hours before the first shower to allow the caulking to cure properly.

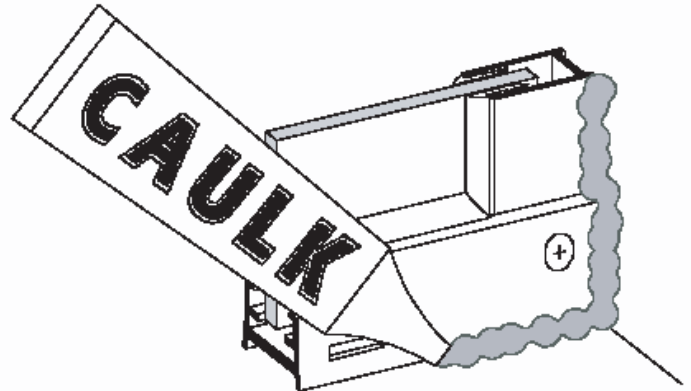

---

---

# 21

Peel off the backing on the BASCO decal [HH] and apply to the inside surface of the header.

